

**FAMILY OF EARTH SHORT-CIRCUIT
TRANSFORMERS TYPE IO
Operating Manual**



Gliwice, July 2024

Solutions contained within this design may be copied and distributed only as a whole.
Copying and/or use part of this design for may take place only upon a written permission issued
by Energotest Ltd.

Energotest reserve the right for making modifications in products for the purpose of improvement technical quality. These modifications may not be currently taken into consideration in documentation.

Brands and names of products mentioned in instruction are producer's brand and should be considered as registered trade marks.

To contact us:

Energotest Ltd.

Chorzowska 44B

44-100 Gliwice

Phone – Central office: 048-32-270 45 18

Phone – Production Department: 048-32-270 45 18 in. 40

Phone – Marketing: 048-32-270 45 18 in. 26

Fax: 048-32-270 45 17

E-mail – Production Department: produkcja@energotest.com.pl

Internet (www): <http://www.energotest.com.pl>



Copyright 2004 by Energotest. All rights reserved.

MEANING OF OPERATING MANUALS

In case of doubts regarding to appropriate interpretation of manuals content we would necessarily like to ask for explanation to manufacturer.

We will be grateful for any suggestions, opinions and critical remarks of users and so we ask for its transmission written or verbal. This may help us make the manuals easier to use and give consideration to wishes and requirements of user.

Device, to which the manuals has been added, includes impossible to eliminate, potential menace for persons and material values. That is why every person, working at this device or performing any activities connected with operating and service of device, has to be previously trained and has to know potential hazard.

It requires careful reading, understanding and obeying of operating manuals, particularly hints concerning safety.

Table of contents

MEANING OF OPERATING MANUALS..... 3

Table of contents 4

INFORMATION OF COMPLIANCE 5

1 Application of device 5

2 Safety rules 5

3 Technical description 6

4 Technical data..... 7

5 Schedule of applied standards 14

6 Data of completeness 14

7 Installing 14

8 Activation 15

9 Operating 16

10 Storing..... 16

11 Utilization 16

12 Warranty and service 16

13 Ordering 17

INFORMATION OF COMPLIANCE

Device being the subject of this instruction was constructed and prepared and it is manufactured for the purpose of use in industrial environment.

This device is compatible to requirements of Conditions for Technical Acceptance of manufacturer.

Accordance to directives was confirmed by test performed in laboratory of Energotest.

1 Application of device

Earth fault transformers (Ferranti) type IO enable the measurement of earth fault current in the network of middle voltage and they may be installed on three core cables, bundle of one core cables and on busbars. They are dedicated to measure current in network with insulated grounded neutral point and in network with neutral point: insulated through resistor or with use of shunt reactor. These transformers cooperate with arbitrary protection against earth fault current.

2 Safety rules

Information included in this chapter are dedicated to teach the user the right installation, operating and service of unit. There is made an assumption that installing personnel, activating and operating this device is properly qualified and is aware of potential danger connected with working at electrical devices.

The device fulfils all requirements of obligatory standards and rules in scope of safety. Its construction is particularly prepared because of user security.

Installation of device



The installation of device should be carried out at disconnected source of any voltage on cables/busbars.

The device should be installed in place making possible proper environmental conditions specified in technical data. Unit should be properly fastened, protected from mechanical damage and from accidental access of unauthorized persons. Cross-section or type of connecting conductors should be chosen in accordance to instructions given in guidelines below.

Activation of device

During activating it is obligatory to check the nominal table of device and following elements:

- Correctness of screwing of core (applies to measuring transformers with divided core),
- Tighten up conductors on terminals,
- Continuity of earthing circuits,
- Continuity of current circuits,
- Polarity.

Operating of device



The unit should run only in environment specified in technical data. Personnel operating the device should be authorized and acquainted with operating manuals.

Service

After installing the device there is necessary no additional service except periodical check-up required by applicable regulations. In case appearance of any defect the user should turn to producer for help.

The producer offers service in scope of activating, commissioning, warranty and post warranty service. Warranty conditions are described in guarantee card.

Nominal data, informing plates and sticks

It is obligatory to obey and accommodate to hints located on device as descriptions or informing plates and sticks and it is necessary to keep them in proper condition making possible to read from it.

Plates and sticks, which become damaged or illegible, should be exchanged.

3 Technical description

Primary winding for earth short-circuit transformers type IO are three core electroenergetic cables or busbars dedicated for three-core network guided through window of transformer.

The transformers possess two windings:

- measuring one, wined at a uniform rate on the circumference of core, assigned for supplying the earth fault transformer (protection), and also
- auxiliary, wined on the same core as measuring winding, assigned for checking up the protection without necessity of creating force current at the primary side; this winding remains opened during normal operating conditions of transformer.

Measuring winding of transformer with not divided core and also IO-110x250-D type possess designation of k1-l1. Auxiliary winding possess designation of k2-l2. Whereas in transformers with divided core (IO-100-D) appropriately k1-l2 and k3-l3. Front of transformers including description of terminals is shown on drawings below.

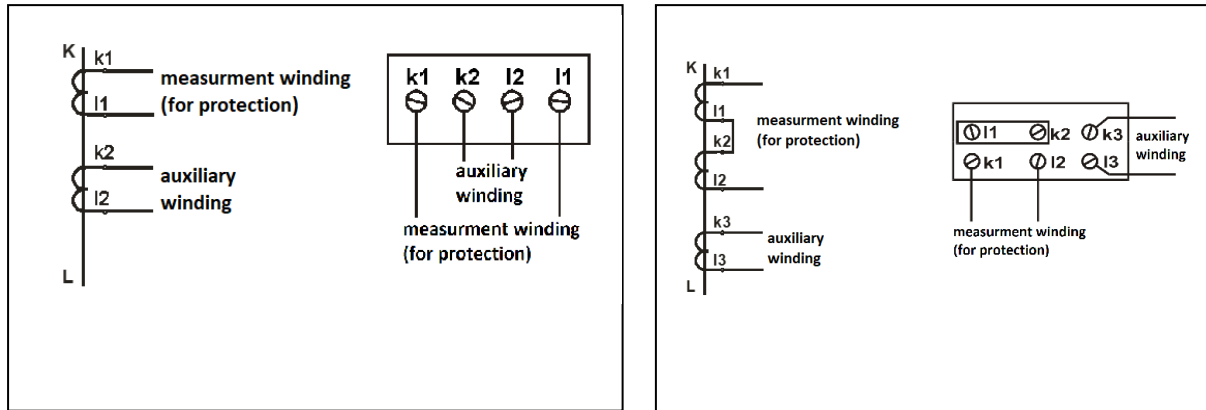

Fig.1 Connecting terminals of earth fault transformers type IO.

4 Technical data

Manufacturer		Production and assembly plant "Magnon" Ltd. 44-100 Gliwice, K. Miarki 12 Street.
Type		Family of earth short-circuit transformers type IO
Secondary side rated current (to choose from)		100 mA lub 1 A
Rated long-term secondary side thermal current		5 A
Rated frequency		50 Hz
Rated load impedance for types ***):		
IO-110x250-N, (IO-12) IO-110x250-D, (IO-12d) IO-125x470-N, (IO-13) IO-125x470-D, (IO13d) IO-70x400-N, (IO-17) IO-280-N, (IO-14) IO-480-N, (IO-15A) IO-695-N, (IO-15) IO-250x450-D, (IO-16)		1 Ω for current 100 mA – 0,01 VA for current 1 A – 1 VA

IO-85-N, (IO-10) IO-125x310-D		
IO-100-N, (IO-11) IO-85-D, (IO-20) IO-100-D, (IO-22e) IO-135-D		2 Ω for current 100 mA – 0,02 VA for current 1 A – 2 VA
Accuracy class		10P
Accuracy limit factor for types ***):		
IO-85-D, (IO-20) IO-100-D, (IO-22e) IO-135-D IO-110x250-D, (IO-12d) IO-125x470-D, (IO-13d) IO-250x450-D, (IO-16) IO-125x310-D		for current 100 mA – 50 for current 1 A – 5
IO-85-N, (IO-10) IO-100-N, (IO-11) IO-110x250-N, (IO-12) IO-125x470-N, (IO-13) IO-70x400-N, (IO-17) IO-280-N, (IO-14) IO-480-N, (IO-15A) IO-695-N, (IO-15)		for current 100 mA – 100 for current 1 A – 10
Current errors in the range below I_N		Acc. to characteristics – fig. 2
Transmission		1:100*)
Auxiliary winding **)		10 coils
Thermal current withstanding capacity – 1 sec.		100 kA (RMS)
Dynamic withstanding capacity		250 kA (RMS)
Electric strength - Measuring and auxiliary windings in relation to each other and to the mounting bracket Primary side		3 kV cable insulation level guided through window of transformer
Insulation resistance		≥ 200 MΩ
Insulation class		Y
Climatic conditions ***): - ambient temperature		

- storing and transport operating		-25 ... +70 °C
- relative humidity		
in ambient temperature of +20 °C		do 90% (max.)
Casing		Epoxide structure
Dimensions		acc. to fig. 3

- *) – upon the client request there exists possibility of realising earth fault transformer of another coil transmission, particularly example 50, 75 or 120.
- ***) - the current injection into the auxiliary winding allows to simulate the primary current and allows to make the all necessary control measurements without the primary current. For example the secondary injection of the 1[A] simulates the 10[A] of the primary current.
- ***) - The previous (old) transformer markings until the end of 2013 are given in parentheses

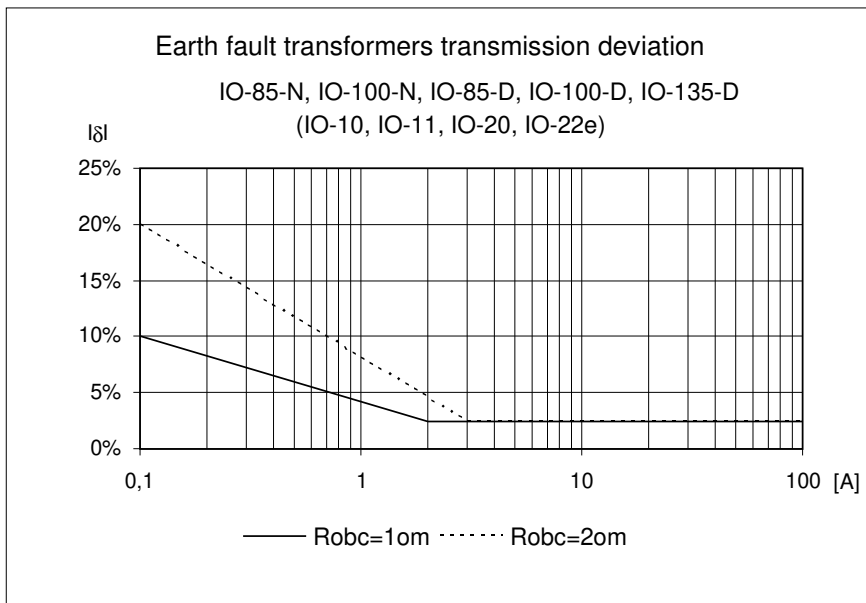

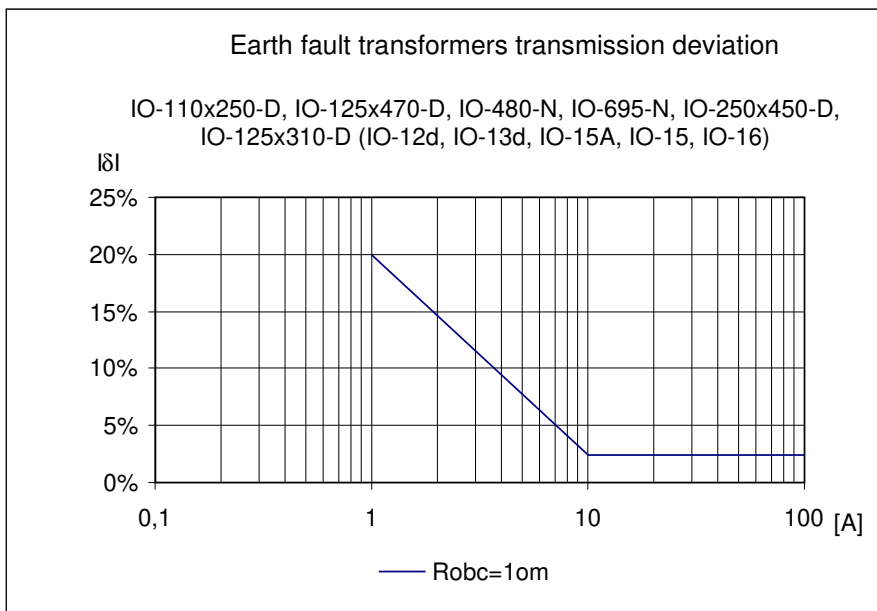
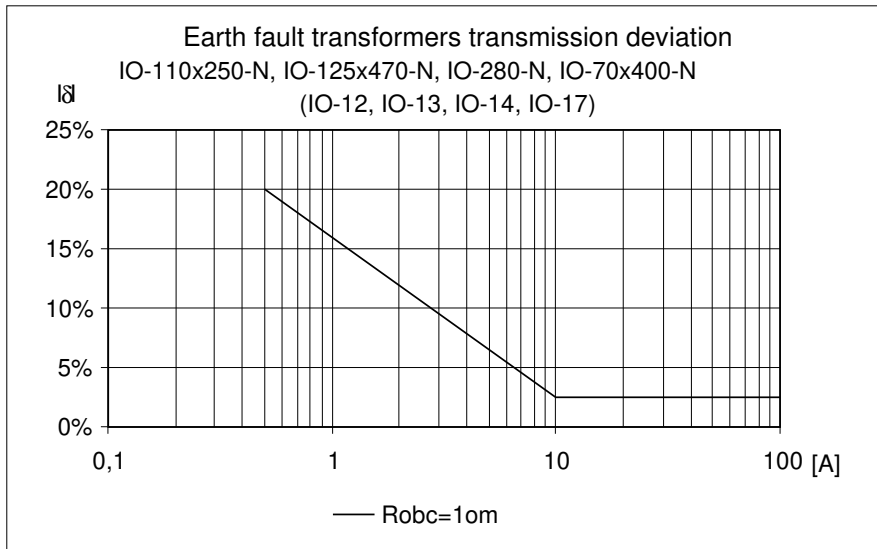
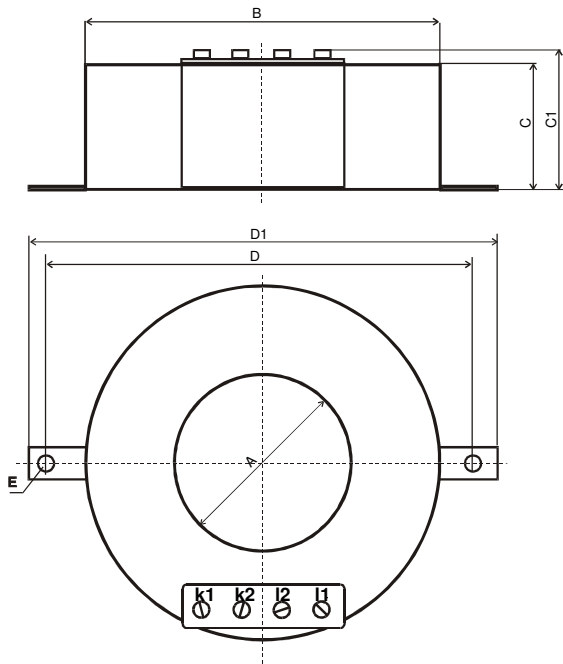
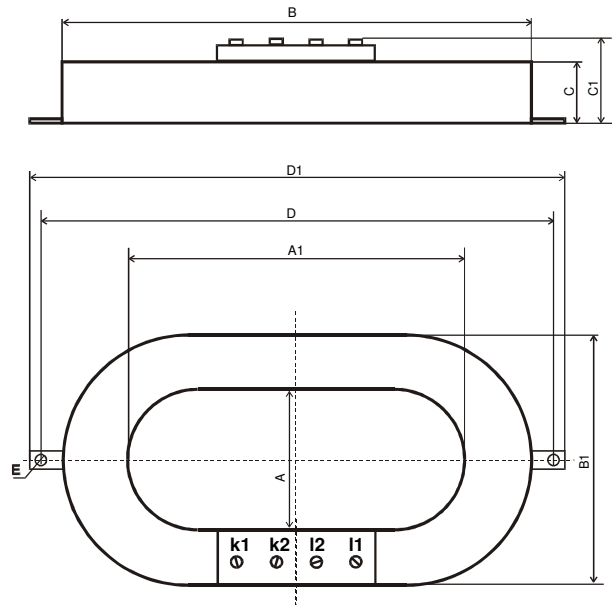

Fig.2 Transmission deviation of earth fault transformers of IO family.



Casing type - I



Casing type - II

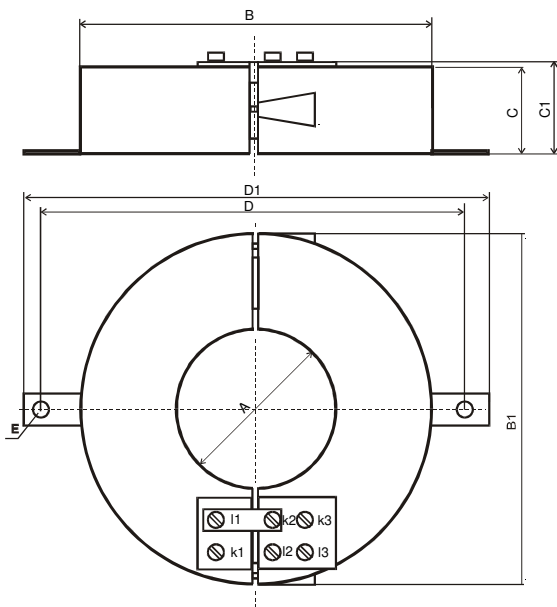

Casing type - III

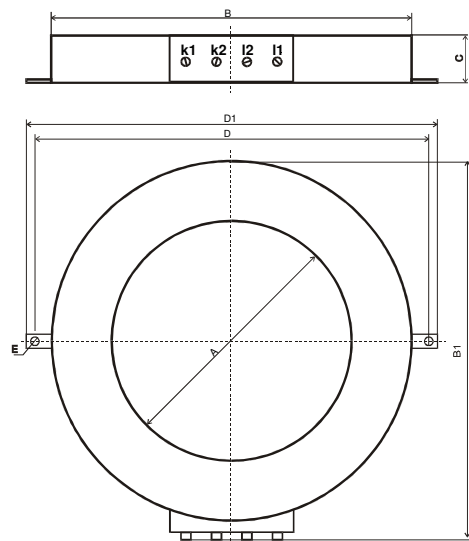

Casing type - IV

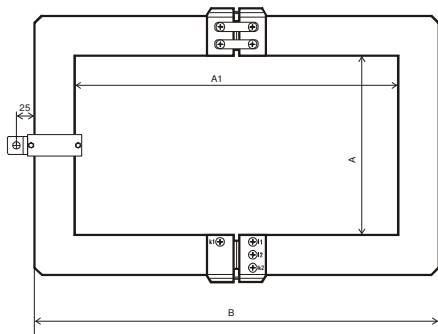

Casing type - V

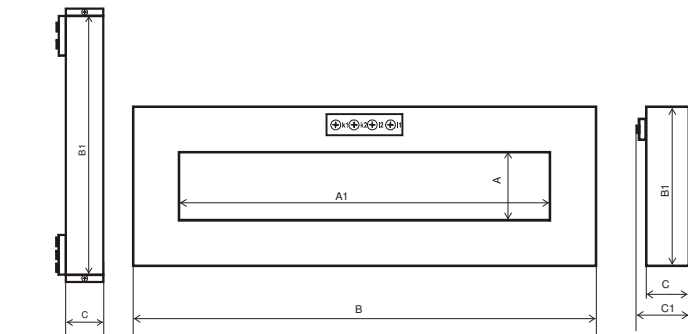

Casing type - VI

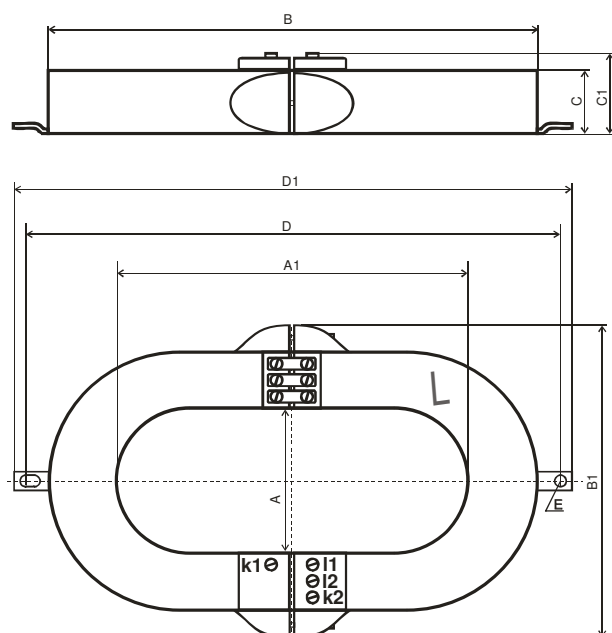

Casing type - VI

Fig.3 Types of applied casings.

Dimensions of casings are described below in chart, units are in mm.

Transformer type	Casing Type	A	A1	B	B1	C	C1	D	D1	E
IO-85-N, (IO-10)	I	85	-	170	-	55	65	200	223	10
IO-100-N, (IO-11)	IV	100	-	214	230	55	-	264	280	10
IO-280-N, (IO-14)	IV	280	-	400	415	55	-	460	480	10
IO-480-N, (IO-15A)	I	480	-	600	-	52	74	*)	-	-
IO-695-N, (IO-15)	IV	695	-	845	-	55	78	*)	-	-
IO-110x250-N, (IO-12)	II	110	250	365	230	55	70	420	440	10
IO-125x470-N, (IO-13)	II	125	470	580	235	53	73	*)	-	-
IO-85-D, (IO-20)	III	85	-	170	190	55	65	200	223	10
IO-100-D, (IO-22e)	III	100	-	220	220	55	72	260	290	10
IO-135-D	III	135	-	260	270	55	72	300	330	10
IO-70x400-N, (IO-17)	VI	70	400	515	187	52	66	*)	-	-
IO-110x250-D, (IO-12d)	VII	110	250	365	267	55	70	410	440	10
IO-125x470-D, (IO-13d)	VII	125	470	580	235	53	73	*)	-	-
IO-250x450-D, (IO-16)	V	250	450	562	361	52	-	*)	-	10
IO-125x310-D	V	125	310	420	235	55	-	*)	-	-

Dimensional tolerance $\pm 3\text{mm}$

*) – transformers are equipped in holders enable to put on casing.

5 Schedule of applied standards

When designing and manufacturing the transformer, such standards were applied, the fulfillment of which ensures the implementation of the assumed rules and safety measures, provided that the user complies with the following installation and operation guidelines. The transformers meet the essential requirements by complying with the following standards.

- PN-EN 60044-1:2000

Transformers. Current transformers.

- WTO-04/Magnon-02

Technical conditions for acceptance. Earth fault transformers type IO

6 Data of completeness

The complete delivery for recipient includes:

- earth fault transformers,
- guarantee certificate together with protocol of test report for product.

Operating manuals is delivered with on charge individually upon clients request.

7 Installing

During assembling works of earth fault transformers there should be paid special attention on cable in order to place it central in the window of transformer. In case of applying single core cables before introducing it into window of transformer it is necessary to put them maximally close to each other and place it central in the window.

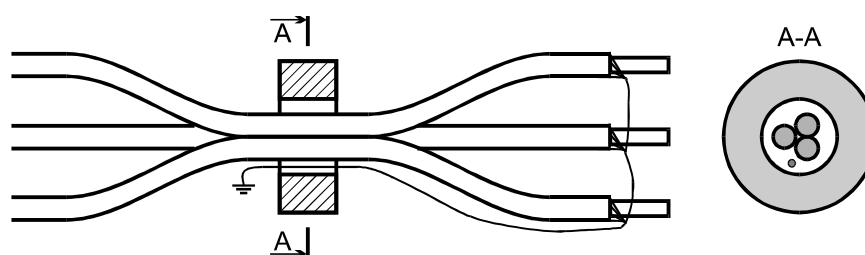

Fig.4 Way of introducing one core cables into window of earth fault transformers.

For the purpose of appropriate operation of earth fault transformers very important thing is to correctly earth of cable armouring. Way of guiding the earthing system is shown on drawing below.

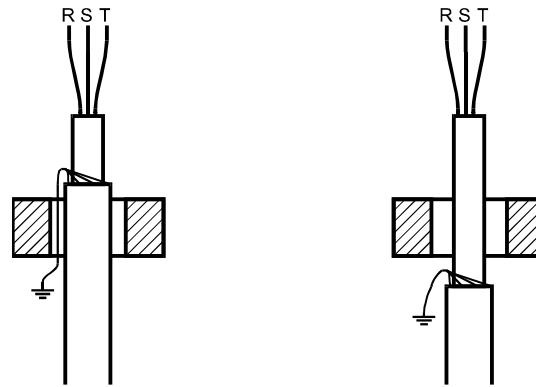

Fig.5 Way of earthing the cables with earth fault transformers set up.

In case of applying earth fault transformers with divided core there should be paid attention on correct screwing the core. Place of putting together both halves should be clean in order to ensure adjoining the core on whole surface. Simultaneously there will be saved minimal air-gap. Before screwing the core both contact surfaces of core halves should be lubricated with no-acid lubricant in order to protect against corrosion.

Structure of transformers with divided core allows for screwing the both halves of core with use of only two screws, which facilitates assembling on existing cables.

Current circuits of earth fault protection should be connected into terminals k1-l1 or k1-l2 (see figure 1)

Auxiliary winding k2-l2 or k3-l3 (see figure 1) should be delivered into terminal strip and leave opened.

The current injection into the auxiliary winding allows to simulate the primary current and allows to make the all necessary control measurements without the primary current. For example the secondary injection of the 1[A] simulates the 10[A] of the primary current.

During operating the transformers do not require any special maintenance operation, and any periodical inspection should be realised in accordance to requirements of operating maintenance of switchgear, where the transformers are installed.

8 Activation

Before giving up voltage on busbars of switchgear there should be checked:

- Correctness of connection between transformer and cooperating protection,
- Screwing up conductors on terminals of transformer,
- Continuity of current circuits,
- Miliammeter of resistance not more than 1 Ω , lack of current on secondary side of transformer (k1-l1 or k1-l2) at lack of current on primary side of transformer (operating conductors of cable are earthed),

- Correctness of screwing the core (for divided cores) by current measurement on secondary side at forced primary current of value about 100 mA; obtained result not more than 20% of analytical current following from coil transmission, testifies for correct screwing the core.

9 Operating

Earth fault transformer made by Energotest are constructed in such way, not to require from user any special exploitation performance.

10 Storing

Transport packing should have the same resistance degree for vibrations and strokes, as specified in standards PN-EN 60255-21-1:1999 and PN-EN 60255-21-2:2000 for sharpness class 1.

The device delivered by producer should be unpacked carefully, not with use of too much strength and not adequate tools. After unpacking it should be visually checked if the device has no outside damage.

The device should be stored in dry and clean place and the temperature of storage is at range of from -25°C up to $+70^{\circ}\text{C}$.

Relative humidity should be in such range, to make possible avoiding condensation and hoarfrost effect.

11 Utilization

If there is necessary to disassemble the device (and eventually removal), as the result of damage or operation life time finish, than there should be previously switched off all the supplying, measuring units and other connections.

Disassembled device should be received as electronic scrap which should be treated in accordance to regulations concerning waste management.

12 Warranty and service

For the delivered automatic unit Energotest gives 12-month warranty calculated from the date of purchasing (unless contract notation says otherwise), based on rules specified in guarantee certificate.

The producer ensures technical assistance at start up of earth fault protection system including earth fault transformers type IO and provides warranty service on the commonly accepted conditions and after warranty service on the conditions mutually agrees on.

Not obeying the rules specified above causes loss of warranty.

13 Ordering

The orders including required type of transformer and coil transmission should be sent to the producer of device into following address:

Energotest sp. z o.o.

ul. Chorzowska 44B; 44-100 Gliwice

tel. 032-270 45 18, fax 032-270 45 17

e-mail: handel@energotest.com.pl

www.energotest.com.pl