



ENERGOTEST

INSULATION CONTROL SYSTEM OF DIRECT CURRENT NETWORK DCtest2 Operating Manual



Gliwice, June 2011

Solutions contained within this design may be copied and distributed only as a whole.
Copying a part of this design may take place only upon a written permission issued by Energotest Ltd.

Energotest Ltd. reserves the right to make modifications in products for the purpose of technical quality improvement. These modifications may not be currently taken into consideration in documentation.

Brands and names of products mentioned in this instruction are producer's brand and should be considered as registered trademarks.

To contact us:

Energotest Ltd.

Chorzowska 44B

44-100 Gliwice

Phone – Central office: +48 32 270 45 18

Phone – Production Department: +48 32 270 45 18 ext. 40

Phone – Marketing: +48 32 270 45 18 ext. 26

Fax: 048-32-270 45 17

E-mail – Production Department: produkcja@energotest.com.pl

Internet (www) <http://www.energotest.com.pl>



Copyright 2004 by Energotest Ltd. All rights reserved.

MEANING OF OPERATING MANUAL

In case of doubts regarding to appropriate interpretation of operating manual content ask necessarily the manufacturer for explanation.

We will be grateful for any suggestions, opinions and critical remarks of users and so we ask for their transmission in writing or verbally. This may help us make the operating manual easier to use and give consideration to wishes and requirements of users.

A device, to which the operating manual has been added, includes impossible to eliminate, potential menace for persons and material values. That is why every person, working at this device or performing any activities connected with operating and service of the device, has to be previously trained and has to know potential hazard.

It requires careful reading, understanding and obeying of the operating manual, particularly hints concerning safety.

Table of contents

MEANING OF OPERATING MANUAL.....	3
Table of contents	4
INFORMATION ON CONFORMANCE.....	6
1 Application of DCtest2 system	6
2 Safety rules	6
3 Technical description.....	8
3.1 General description	8
3.2 Cases.....	8
3.2.1 Cases of central unit.....	9
3.2.2 Cases of concentrators and measuring transformers	10
3.2.3 Portable locator.....	11
3.3 Description of operation	13
3.3.1 General concept of earth faults detection and location system in direct current network	13
3.3.2 Devices being part of DCtest2 system.....	14
Central unit	15
Measuring transformers.....	19
Concentrator.....	20
Portable locator	21
3.3.3 Operation of server central units in one direct current network.....	22
DCtest2 system in a main switching station and switching substations	23
System DCtest-2 in two-section switching station	26
3.3.4 DCtest2 system cooperation with other insulation condition control systems of direct current network	27
4. Technical data	28
5 Schedule of applied standards	30
6 Data on completeness.....	31
7 Installation	32
7.1 General information.....	32
7.2 External connections.....	32
7.2.1 Connection of central unit.....	32
7.2.2 Connection of measuring transformers.....	33
7.2.3 Connection of concentrator.....	34
7.2.4 Connection of portable locator	34

7.3	Communication connections	35
7.3.1	Connections between central unit and measuring transformers (RSA)	35
7.3.2	Connections between central units	37
7.3.3	Connection between central unit and portable locator	38
7.3.4	Connection with Supervision and Control System	38
	Bit number	40
8	Activation.....	47
8.1	General information.....	47
8.2	Parameters set in DCtest2 system.....	48
8.3	Functions of push-buttons on front panel.....	48
8.4	Way of entering setpoints.....	49
8.5	Location of earth fault.....	51
8.5.1	Location of earth fault in direct current network in which all outgoings are measured 51	
8.5.2	Location of connections between circuits and connections between batteries.....	52
8.5.3	Location of earth fault in direct current network using portable locator	54
	Activation of device.....	55
	Calibration	55
	Performance of measurements	56
9	Operation	57
9.1	Routine tests	57
9.2	Detection and elimination of damage.....	58
10	Transport and storage.....	58
11	Utilization.....	58
12	Warranty and service	58
13	Ordering	59

INFORMATION ON CONFORMANCE

The DCtest2 system being a subject-matter of this operating manual is constructed and manufactured for the purposes of industrial environment applications.

The devices of DCtest2 system are conformed to the provisions of the following directives:

73/23/EEC low voltage directive – the Ordinance of the Minister of Economy, Labour and Social Policy dated 12.03.2003 (Journal of Laws, No. 49, item 414) and 89/336/EEC electromagnetic compatibility – the Ordinance of the Minister of Infrastructure dated 02.04.2003 (Journal of Laws, No. 90, item 848).

The conformance to the directives is confirmed by the tests performed in the Energotest's laboratory and in measurement laboratories and research and develop centres independent of the manufacturer in accordance with the requirements of harmonised standards: PN-EN 60255-5 (for the LVD directive) and PN-EN 50082-2 and PN-EN 50263 (for the EMC directive), and also for other standards (see item 5 of the operating manual).

1 Application of DCtest2 system

The DCtest2 system is intended to control an insulation condition of direct current networks insulated from the ground potential with a possibility of location of outgoings shorted to ground. The systems helps to control continuously the insulation resistance of the network in relation to ground and in relation to other galvanically earthed circuits (e.g.: 230/400V AC) and to locate the outgoings shorted to ground.

A correct operation (accurate measurements, precise earth fault location) of the DCtest2 system, under conditions of large disturbances appearing in DC networks, is possible thanks to use of modern compensation and filtration systems of measuring signals.

2 Safety rules

The information included in this chapter is dedicated to acquaint the user with the right installation and service of the devices being part of the DCtest2 system. There is made an assumption that the installing personnel, activating and operating this device is properly qualified and is aware of potential danger connected with working at electrical devices.

The device fulfils all requirements of obligatory regulations and standards within the scope of safety. Its construction is particularly prepared because of the user's security.

Installation of the device

The devices of the DCtest2 system should be installed in place making possible proper environmental conditions specified in technical data. The devices of the DCtest2 system should be properly fastened, protected from mechanical damage and from accidental access of unauthorized persons. A central unit is available in a surface-mounted case or a flush-mounted case, depending on a case version.

Concentrators and measuring transformers are adapted to installation on a TS-35 bus.

The individual devices of the system should be connected according to the electric diagram.

External connections are delivered through disconnectable connectors of WAGO type and through DB9 drawer connectors. LY-type conductors of 0,5...1,5 mm² cross-section are recommended to utilize for the connections.

The cases of some versions of central units require to connect the earth to earthing terminals.

Activation of the device

After the installation of the DCtest2 system it should be activated in accordance with the generally accepted rules related to the protection devices, instrumentation and control.

Operation of the device



The device should run in conditions specified in the technical data.

The personnel operating the device should be authorized and acquainted with the operating manual.

Removal of the case



Before the commencement of any duties connected with a necessity to remove the case of the device all the supplying and measuring voltages should be absolutely disconnected and then the device should be disconnected from external circuits by removing all the plugs.

The applied subassemblies are very sensitive to electrostatic discharges and therefore the opening of the device without special anti-electrostatic equipment may cause its damage.

Service

After the installation the devices do not request any extra services with the exception of routine tests which are required by appropriate regulations. In case any defect is detected the user should turn to the manufacturer for help.

The manufacturer offers services within the scope of activation and warranty and post-warranty services. The warranty terms are described in a warranty card.

Modifications and changes

Because of the security matters all the modifications and changes of functions of the device to which this operating manual refers are forbidden. The modifications of the device not certified in writing by the manufacturer cause the loss of any liability claim in relation to Energotest Ltd.

The replacement of elements and subassemblies being part of the DCtest2 system and coming from other manufacturer than already applied may cause hazard for the users and eventually result in incorrect functioning.

Energotest Ltd. does not bear responsibility for damages caused by applying inappropriate elements or subassemblies to the device.

Disturbances

It is strongly advised to immediately inform an authorised person of any disturbances and other damages noticed during operating. Any repairs may be realized only by qualified specialists.

Name plates, information plates and labels

It is obligatory to obey to the hints given in the form of descriptions on the device, information plates and labels and it is necessary to keep them in a proper condition ensuring good readability. The plates and labels that are damaged or illegible should be replaced.

3 Technical description

3.1 General description

The DCtest2 system ensures:

- measurement of insulation resistance of the entire network in relation to ground,
- signalling of lowering of insulation resistance of controlled network below the set value,
- immediate location of earth fault in any measured outgoing without a necessity to switch off the circuits,
- location of earth fault in unmeasured outgoings by means of portable locator.

The DCtest2 system has additional functions: detection and location of connections between circuits and connections between batteries.

3.2 Cases

The cases of individual devices being part of the DCtest2 system are presented in figures 1 ... 3. The connector plugs are represented by a dashed line and described by DB9 and WAGO connector types in figure.

3.2.1 Cases of central unit

A central unit is produced in three case versions:

- 19-inch flush-mounted case intended to build in a typical cabinet adapted to installation of 19-inch cassettes (figure 1),
- 14-inch flush-mounted case intended to build in a mimic panel in the control room or onto a switchgear elevation (figure 2),
- surface-mounted case intended to build in a relay board or onto a rear wall inside a relay section of the switchgear or inside a cabinet (figure 3).

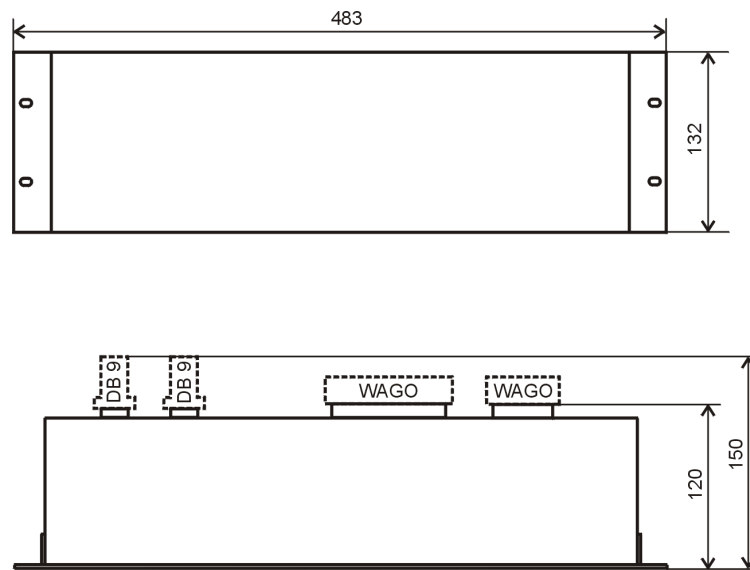

Figure 1. Dimensions of 19-inch flush-mounted case.

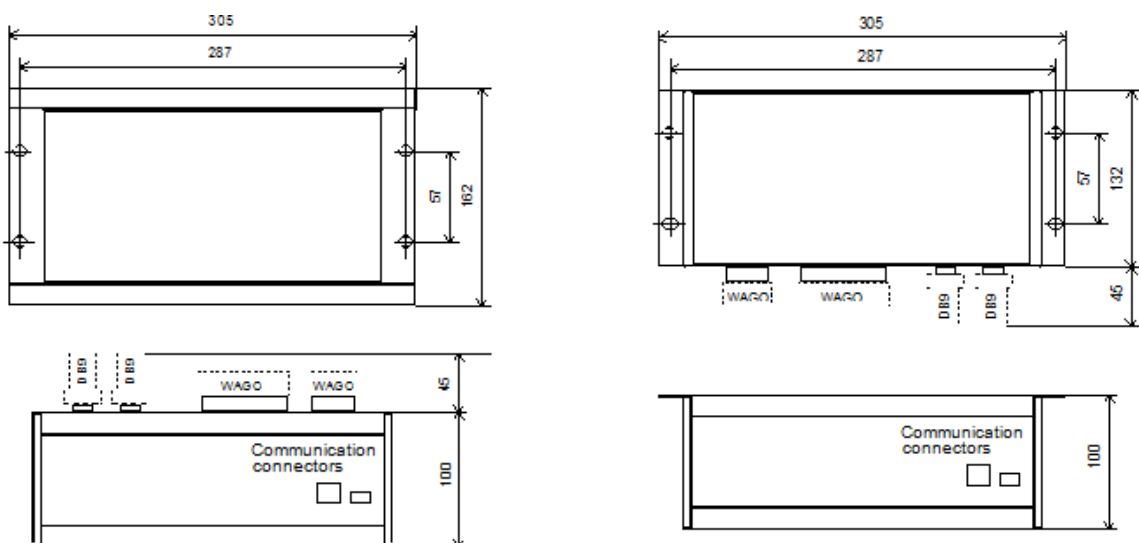

Figure 3. Dimensions of surface-mounted case

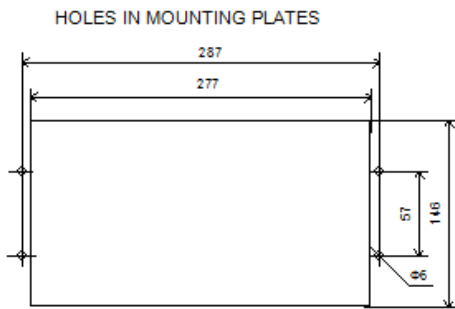

Figure 2. Dimensions of 14-inch flush-mounted case

3.2.2 Cases of concentrators and measuring transformers

The concentrators and measuring transformers are adapted to installation on a TS-35 bus.

The DC2-k concentrators have CN100 cases made by Bopla,

The measuring transformers differ in dimensions of a hole for leading conductors of primary circuit.

The dimensions of the hole are presented in the type of transformer.

The dimensions of concentrator and measuring transformers are presented in figures 4, 5 and 6

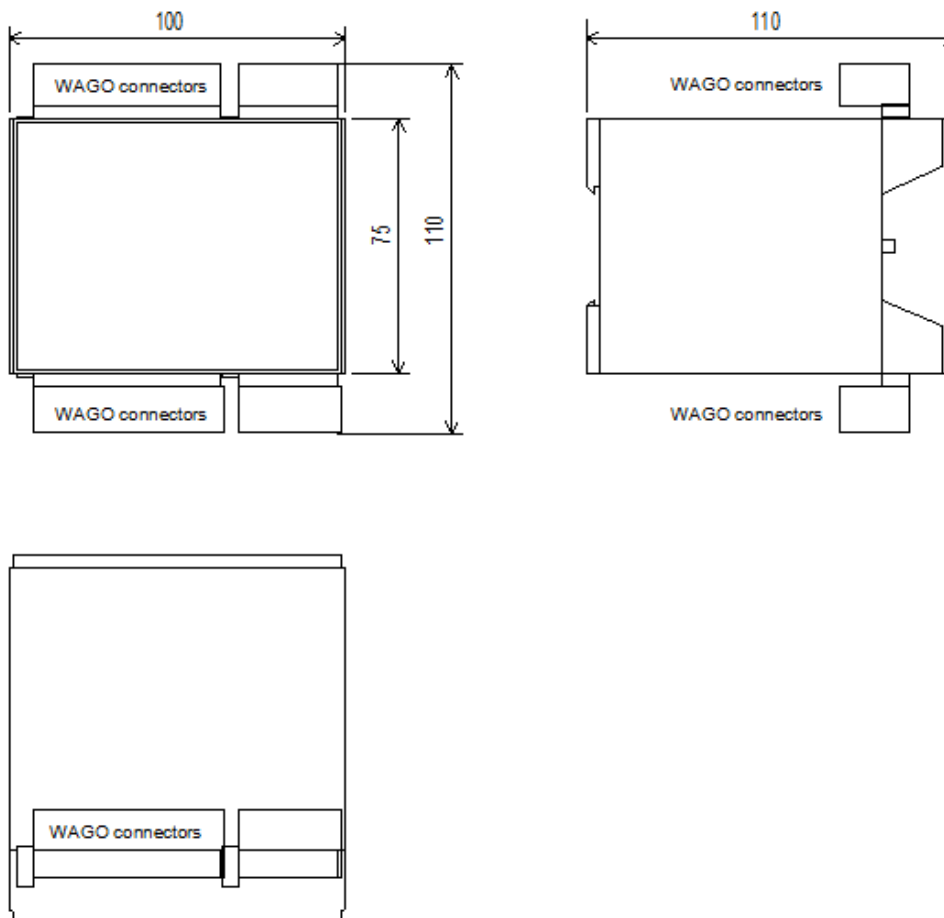

Figure 4. Dimensions of concentrator

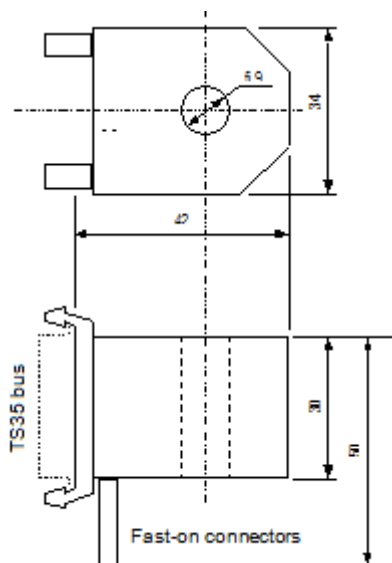

Figure 5. Dimensions of DC2-I9 measuring transformer

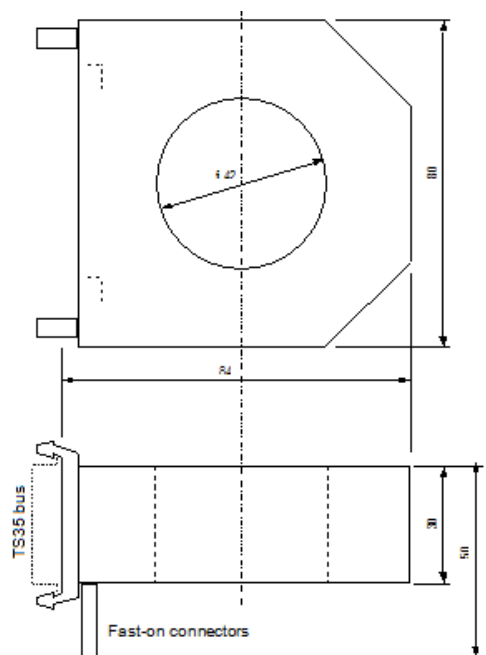

Figure 6. Dimensions of DC2-I43 measuring transformer

3.2.3 Portable locator

The dimensions of portable locator pincers and hanger are presented in figures 7 and 8.

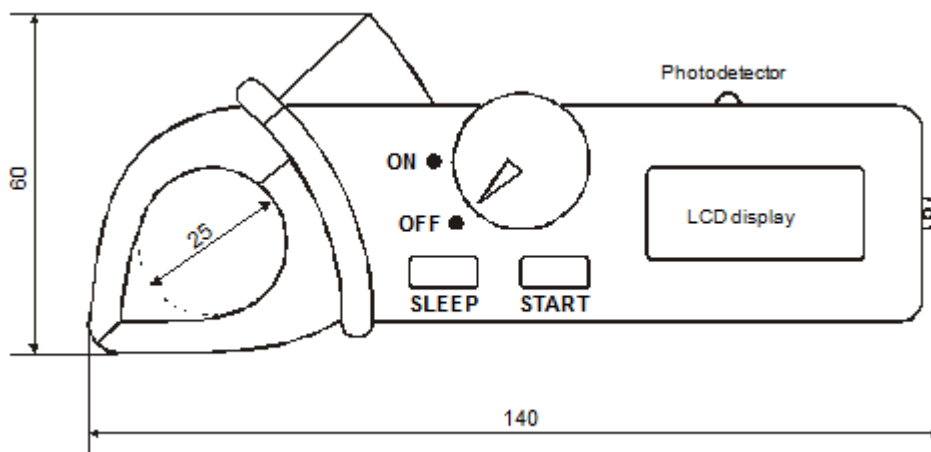

Figure 7. Dimensions of DC2-p portable locator pincers

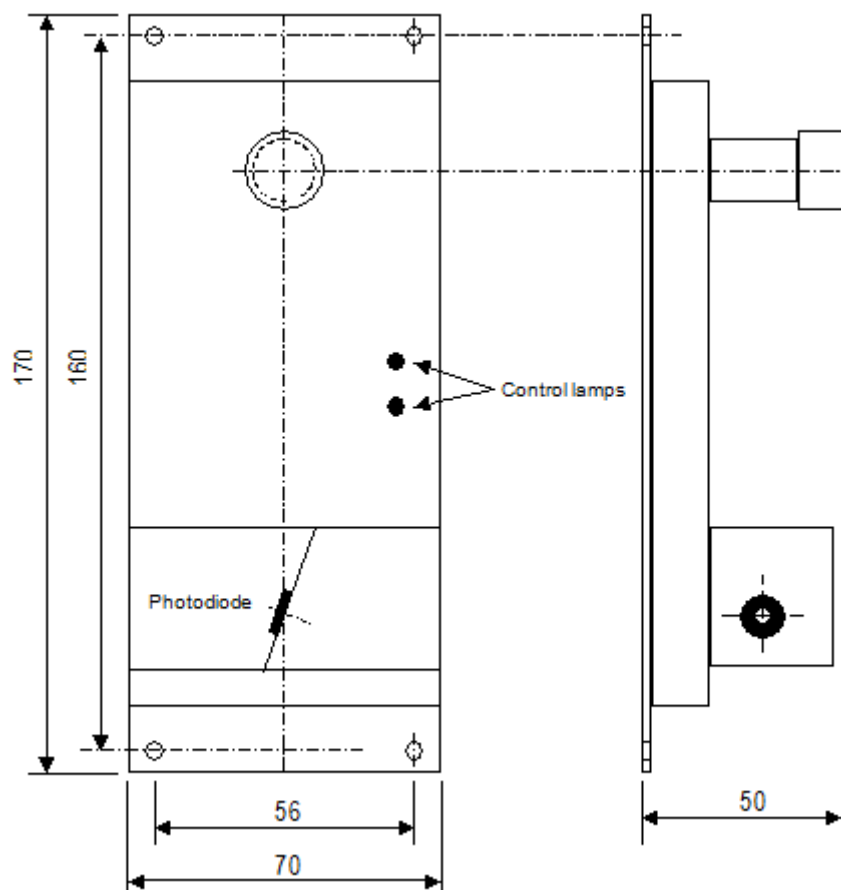

Figure 8. Dimensions of DC2-p portable locator hanger

Other parameters of the cases of the devices

The mass of the individual devices and protection classes of the cases are listed in the table:

Unit	Mass in kg	Protection class:
DC2-jc central unit in a surface-mounted case	5,0	IP52
DC2-jc central unit in a 19-inch surface-mounted case	6,0	IP40
DC2-jc central unit in a 14-inch surface-mounted case	5,5	IP40
DC2-k concentrator	0,1	IP5X
DC2-l measuring transformers (depending on the type)	0,2 ... 0,5	IP5X
DC2-p portable locator		
Portable transformer hanger		

3.3 Description of operation

3.3.1 General concept of earth faults detection and location system in direct current network

A DCtest2-type microprocessor insulation condition control system of direct current network fulfils the basic functions:

- controls continuously the value of insulation resistance of the entire monitored direct current network,
- ensures a quick location of the outgoing shorted to ground.

A measurement principle of insulation resistance consists in inducing a proper voltage signal between each of the network's poles and ground, and then in measuring a distribution of currents forced by this signal. It is presented in figure 9.

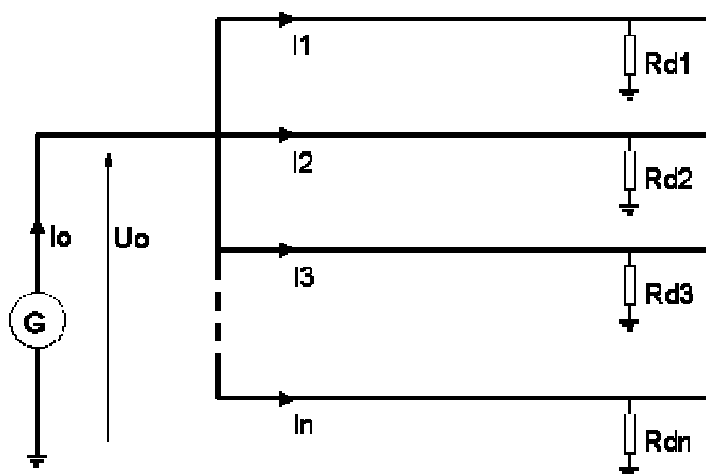

Figure 9. Principle of operation of DCtest2 system.

A voltage signal between a monitored network and ground is formed by a generator whose operation consists in connecting both poles with ground through elements of known resistance. The amplitudes of induced voltage U_o and total ground current I_o are measured to determine the total insulation resistance of the network R_o . The insulation resistance of the network is calculated on the basis of $R_o = U_o / I_o$ dependence. The voltage U_o is measured by a voltmeter attached to the generator output, the current I_o is measured by an ammeter connected between the generator and ground.

The currents I_n in individual outgoing are measured by means of measuring transformers.

The calculated value of insulation resistance of given outgoing concerns only this fragment of the network which is physically at the opposite side of the measuring transformer than the generator.

3.3.2 Devices being part of DCtest2 system

A basic system that realizes a described measurement principle consists of the following elements:

- one DC2-jc-type central unit that is “a heart” of the entire system,
- DC2-lw-type measuring transformers (where: w – means the dimensions of a window given in mm) located in individual outgoing,
- DC2-k-type concentrators (up to 8 measuring transformers can be connected to one concentrator),

A DC2-p portable locator completes the stationary system. It is employed to control the outgoing in which the measuring transformers are not built in and it ensures a precise location of damage place of the insulation as well.

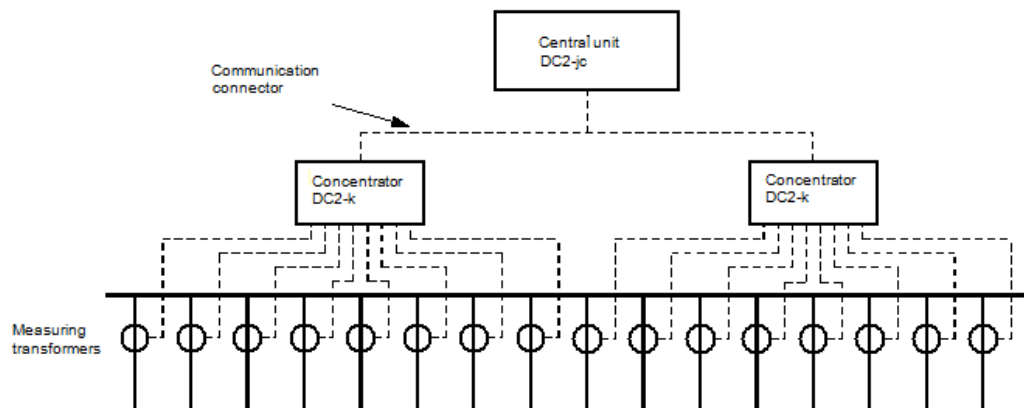

Figure 10. Diagram of basic measuring system for exemplary switching station in which 16 outgoing are measured.

The main elements of the system are located in the central unit. It is most advantageous to install the central unit on the switchgear elevation or in the control room. The measuring transformers and concentrators should be installed in the direct current switchgear.

The measuring system elements are connected with the central unit through an RS485 communication connector called RSA.

The insulation condition control system can be built on the basis of one central unit together with measuring transformers connected with it by means of concentrators (it is the simplest version of the system) or it can be developed to several autonomous measuring systems cooperating with each other.

The need to use several central units in one network appears in case the DCtest2 system is employed in the main switching station and in switching substations as well as in case the consuming systems are supplied from one or from two batteries of accumulators depending on an

operation system configuration of direct current network. At that time each unit is connected with a determined group of measuring transformers forming a separate measuring system. If several central units work in one direct current network it is necessary to privilege one of them (this unit shall be a master). The central units can communicate with each other through the RS485 connector called RSB.

The cases of application of developed measuring system consisting of several central units are described in item 3.3.3 in detail.

Central unit

A central unit is a basic element of the system and it is equipped with:

- generator inducing measuring signals in the direct current network,
- voltmeter measuring an amplitude of induced voltage,
- ammeter measuring the total ground current,
- calculation system of insulation resistance of the entire network,
- two $R < t$ measuring elements controlling a resistance value of the network equipped with additional time elements,
- system of internal signalling,
- system of external signalling,
- visualisation system of measurement results with a LCD display,
- system of communication with concentrators,
- system of communication with other central units

Generator, voltmeter and ammeter

A generator operation concept and voltmeter and ammeter connection is shown in figure 11.

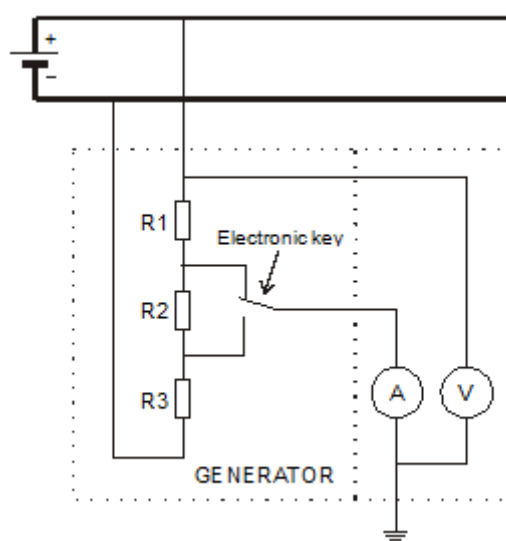

Figure 11. Generator operation concept and voltmeter and ammeter connection.

An electronic key presented as a switchable contact in the diagram causes an alternate shorting of two points of resistance divider.

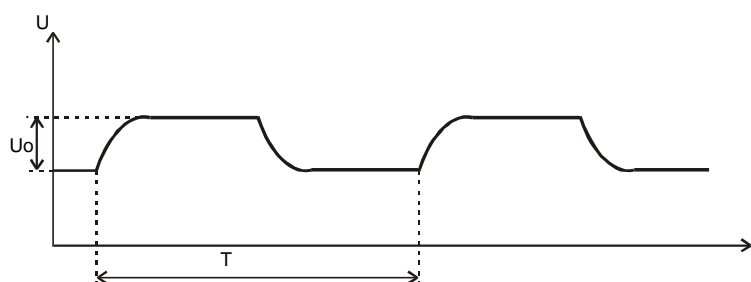

Figure 12. Shape of output generator pattern.

A voltage amplitude U_0 depends on the resistance of the entire network and fluctuates within the limits from approx. 50 % of voltage value of the direct network current in case of the lack of earth fault, to zero in case of metallic earth fault in the network. A time constant of signal rise and fall depends mainly on the ground capacity of the direct current network and amounts to 50 ms at least.

One generator only can work in one direct current network. If several central units work in one network it is necessary to privilege one of them (this unit shall be a master) and to lock the generators in other ones. The generator can be locked by closing input terminals in the A4-A5 central unit.

The insulation resistance of the entire network is calculated on the basis of information on the value of voltage U_0 and current I_0 . If a reduction of resistance of both positive and negative pole appears in the direct current network, the total resistance is a resultant of both of them connected in parallel.

The knowledge of the insulation resistance value of the entire network is employed in measuring elements R<t 1st and 2nd degree. They are employed to signal emergency conditions. They include two measuring elements with additional time delay. The start-up values and operation times of both elements are set independently of each other.

The measuring elements function with purposefully entered time delay. The excitation and de-excitation is delayed by 10...20 s. The delay is set to ensure a separation from disturbances appearing in the direct current network in relation to the ground potential.

Front panel

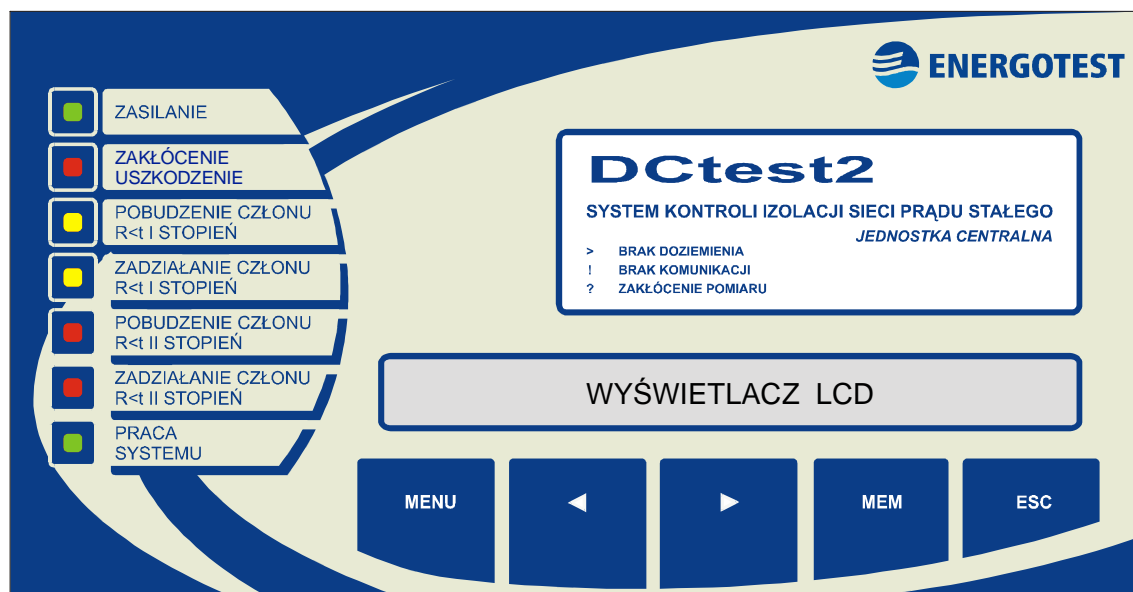

Figure 13. View of central unit front panel.

The front panel is divided into the following segments:

- on the left there are lamps signalling a system operation condition and an insulation condition of the direct current network,
- results of measurements performed by the system are presented on the liquid crystal display,
- under the display there are push buttons employed to change the presentation mode of information on the display and to enter setpoints.

System of internal signalling,

The lamps located on the front panel signal an insulation condition of the direct current network and a system operation condition:

- “Supply” – signals a connection condition of central unit.
- “Disturbance, failure” – in yellow – signals disturbances (failure of measuring transformer, disturbance in measurement of ground current of the outgoing) and – in red – failure of concentrator (break in a communication connector with the concentrator or the lack of supply voltage of the concentrator).
- “Excitation of element R<t 1st degree” – signals the excitation of element R<t 1st degree,
- “Tripping of element R<t 1st degree” – signals the tripping of measuring element R<t 1st degree with time delay,
- “Excitation of element R<t 2nd degree” – signals the excitation of element R<t 2nd degree,
- “Tripping of element R<t 2nd degree” – signals the tripping of measuring element R<t 2nd degree.

- "Operation of system" – a blinking lamp – signals the operation of the system.

During a regular operation of the system the "Supply" lamp should flash and the "Operation of system" lamp should blink.

System of external signalling,

The central unit is equipped with the following external contacts signalling an insulation condition of the direct current network and operation condition of insulation control system:

- "Failure of supply" – signals the failure of the central unit supply,
- "Disturbance, failure" – in yellow – signals disturbances (failure of measuring transformer, disturbance in measurement of ground current of the outgoing) and – in red – failure of concentrator (break in a communication connector with the concentrator or the lack of supply voltage of the concentrator).
- "Excitation of element R<t 1st degree" – signals the excitation of element R<t 1st degree,
- "Tripping of element R<t 1st degree" – signals the tripping of measuring element R<t 1st degree,
- "Excitation of element R<t 2nd degree" – signals the excitation of element R<t 2nd degree,
- "Tripping of element R<t 2nd degree" – signals the tripping of measuring element R<t 2nd degree.

During a regular operation of the system all the contacts of external signalling should be opened.

Note:contacts of excitation elements R<t 1st and 2nd degree (B5-B6 and B9-B10 terminals) are intended for testing purposes.

Visualisation system of measurement results with a LCD display

U=041V		Str		SIEC		R6.S1		RM1		PZ3		RK5		
w/g	<>	001		010k+		016k		025k		>	k		>	k

Figure 14. Exemplary view of LCD display page.

The display presents in sequence from the right:

- value of insulation resistance of the outgoings. If there are more than 4 measured outgoings, the subsequent outgoings are displayed by pages, 4 on each page. The name of the outgoing given in the top line can consists of 5 marks, including letters, figures and punctuation marks.
- value of ground resistance of the entire network and information on which pole is shorted to ground (+ or -),
- page number with individual outgoings,
- way of presentation of sequence of individual outgoings:

< > - according to the resistance value (it is a basic mode) at that time the outgoings in which there is earth fault are displayed at the beginning and after them the outgoings signalling a transformer condition, i.e. “!” , “?” , “>” are displayed in turn,

number - according to rising code numbers of individual transformers,

- value of voltage induced in the direct current network in relation to the ground potential.

The marks signalling a condition of measuring transformer and outgoing are the following:

> - signals the lack of earth fault,

! - signals the lack of communication with the concentrator. It can be caused by:

- failure of concentrator,
- break in a communication connector,
- lack of concentrator supply.

? - signals the measurement disturbances of outgoing ground current. The transformer is exposed to external disturbances that are eliminated automatically through a transformer calibration. The calibration is activated also after switching on the supply of transformers. If a question mark flashes all the time it can be caused by:

- appearance of disturbances of large amplitude in the ground current,
- appearance of constant component of large value caused by closing between two circuits

in the ground current (the currents in a positive and negative conductor are not compensated),

- magnetization of magnetic circuit of measuring transformer,
- break in a winding of measuring transformer,

During a proper operation if there is no earth fault in the direct current network the mark “>” should appear in all the outgoings.

Measuring transformers

The measuring transformers, built in measured outgoings, are employed to perform measurements of ground currents of individual outgoings.

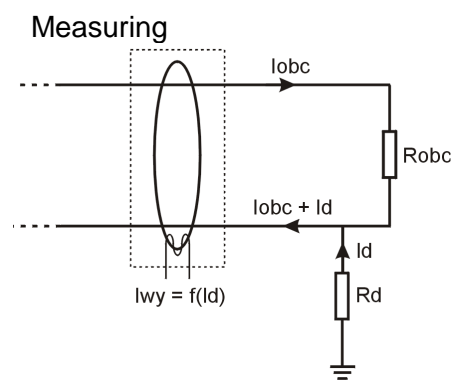

Figure15. Principle of operation of stationary measuring transformer.

The number of measuring transformers in the system depends on the operation needs, i.e. it depends on how many outgoing should be measured. Up to 100 (optionally up to 200) measuring transformers can be connected to on central unit.

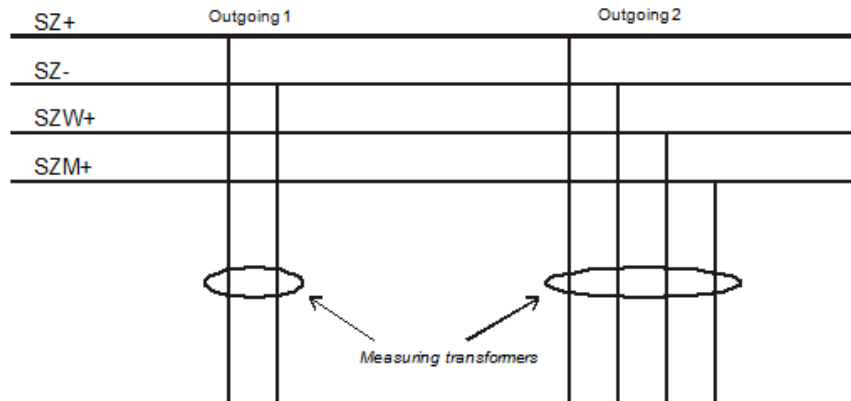

Figure 16. Connection of outgoing to buses of direct current switching station.

The outgoing can be supplied by a various number of conductors. The outgoing No. 1 is supplied by two conductors from a positive and negative bus. The outgoing No. 2, apart from these two (positive and negative) conductors, has additional conductors supplying a signalling system. Three conductors are on a plus potential and only one is on a minus potential. The current flowing through these three positive conductors flows out through one negative conductor and to compensate these currents of working load it is necessary to bring 4 conductors through the measuring transformer window.

Concentrator

The current impulses measured by measuring transformers are entered into the concentrator where the value of ground current is calculated. The values of ground current and the value of resistance of outgoing, and the test voltage U_0 , and the ground resistance of the entire network R_s can be read on the display.

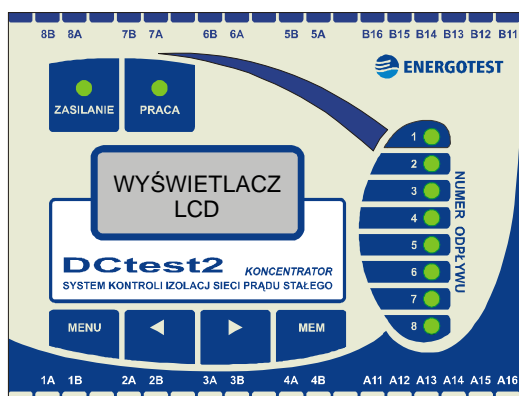

Figure 17. View of concentrator front panel.

The front panel includes the following elements:

- concentrator operation condition signalling lamps,
- outgoing condition signalling lamps.
- LCD display on which the results of measurements performed by the system are presented,
- push buttons employed to change the presentation mode of information on the display and to enter setpoints.

During a regular operation of the system the “SUPPLY” lamp should flash and the “OPERATION” lamp should blink. The colours of outgoing condition signalling lamps mean the following:

- green means the lack of earth fault,
- red means the earth fault in the outgoing ($R_d < 5 \text{ km}$),
- yellow means disturbances (e.g.: break in a winding of measuring transformer or incorrectly entered numbers of measuring transformers)

The values of ground currents and insulation resistance of outgoings as well as the value of voltage induced in the direct current network in relation to the ground potential, and the value of ground resistance of the entire network are presented on the LCD display concurrently with the light signalling.

When the lamp does not flash it means that the measuring transformer is not connected and logged in.

During a proper operation, if there is no earth fault, the outgoing condition signalling lamps should flash green and the “>” mark should appear in all the outgoings on the LCD display.

The concentrator is available in two versions:

- the 1st version – basic – ensures the reading of ground resistance of outgoings measured by the central unit. The value of generator voltage and the value of ground resistance of the entire network can be read on the concentrator displays of this version.
- the 2nd version – with voltage measurement – is employed in the systems when a large number of sub-switchgears located at a significant distance are supplied from the main switchgear, e.g.: the supply of kiosks on the power node. Up to 7 measuring transformers can be connected to the concentrator of this version. The value of generator voltage can be read on the concentrator displays of this version.

Portable locator

The portable locator completes an earth fault location stationary system and it is employed to measure ground currents in the outgoings in which stationary measuring transformers are not installed.



Figure 18. View of portable locator

The portable locator is equipped with current pincers by which both conductors (positive and negative) should be embraced during the measurements. The personnel measuring in turn the ground currents of individual outgoings locates an outgoing of worsened insulation resistance. The display presents an insulation conditions expressed in w %, where: 0 – means a full earth fault ($I > 5\text{mA}$), 100 – means the lack of earth fault ($I < 2\text{mA}$).

3.3.3 Operation of server central units in one direct current network

Several central units can operate in one direct current network. The central units are adapted to cooperate with each other. They can communicate and convey information. The programming of cooperation consists in determining operation conditions of each of them (indicating a master) and in locking properly generators and transmitters in individual units.

The cooperation conditions of several central units are as follows:

- RSB transmission network has not to agree with a configuration of direct current network.
- several central units can work in one direct current network but the generator can be activated only in one of them. The generators must be locked in other ones.

The generator can be locked by closing the A4-A5 input terminals of the central unit. A lock of generator is signalled by an asterisk „*” appearing on the liquid crystal display of central unit in place of indication of resistance of the entire network.

Several central units can be connected to one RSB transmission network but the transmitter can be activated only in one of them. The transmitters should be locked by closing the A4-A6 input terminals of the central unit in other ones. When active transmitters are left in several central units the transmitters are locked automatically in the accidental units.

In case of operation of several central units in one direct current network the measurement of ground resistance of the entire network is realized by one of the units, however, a location of earth fault is performed by each of them in “its own” part of the network.

DCtest2 system in a main switching station and switching substations

Exemplary variants of DCtest2 system configurations including main switchgear and sub-switchgears are presented in Figures 19, 21 and 22.

Variant 1:

The central unit and concentrators are installed in the main switchgear.

The central units and concentrators are installed in sub-switchgears.

This variant can be applied in any situation, and in particular when the sub-switchgears can be supplied from various section of the main switchgear or various switchgears.

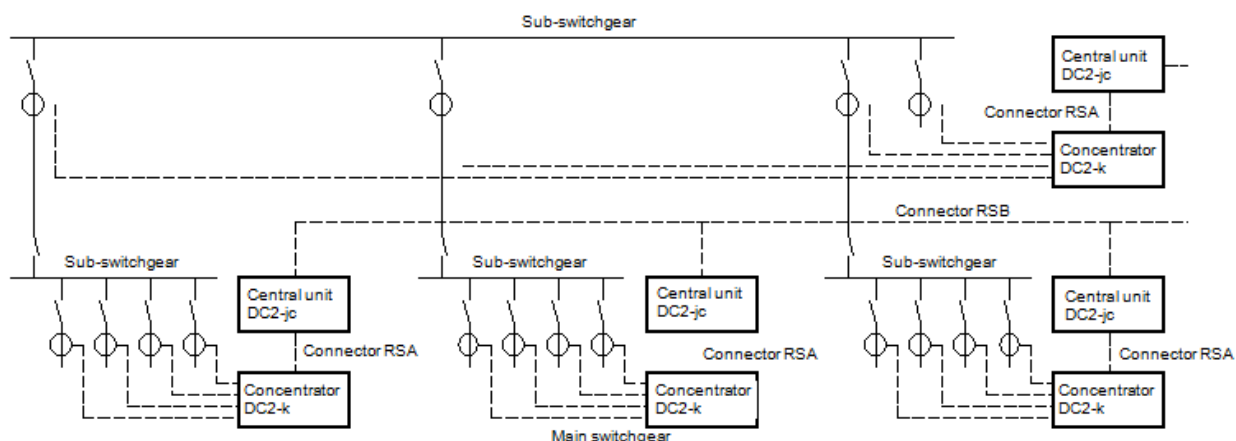

Figure 19. DCtest2 system in the main switchgear and sub-switchgears – variant 1.

Parameter:	Place of reading:
- insulation resistance of the entire network	- central unit in main switchgear, - concentrators in main switchgear, - concentrators in sub-switchgears,
- insulation resistance of outgoings of main switchgear	- central unit in main switchgear, - concentrators in main switchgear,
- insulation resistance of outgoings of sub-switchgear	- central unit in sub-switchgear, - concentrators in sub-switchgear,

The generators should be locked – closed A4-A5 terminals – in the central units installed in the sub-switchgears.

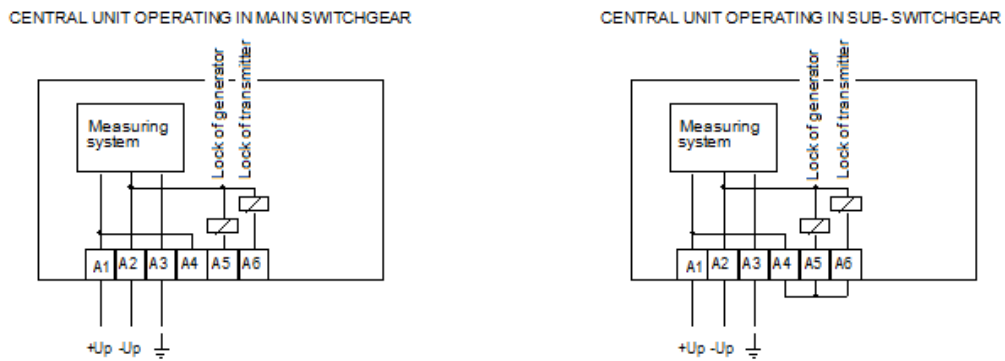

Figure 20. Diagram of locks of central units operating in one network

The excitation and tripping of measuring elements R<t 1st and 2nd degree – are not signalled in the central units operating as slaves (installed in the sub-switchgears).

Variant 2:

The central unit and concentrators are installed in the main switchgear.

The concentrators are installed in sub-switchgears.

This variant is used when the sub-switchgears are supplied only from one main switchgear and it is not possible to supply the sub-switchgears from other sources.

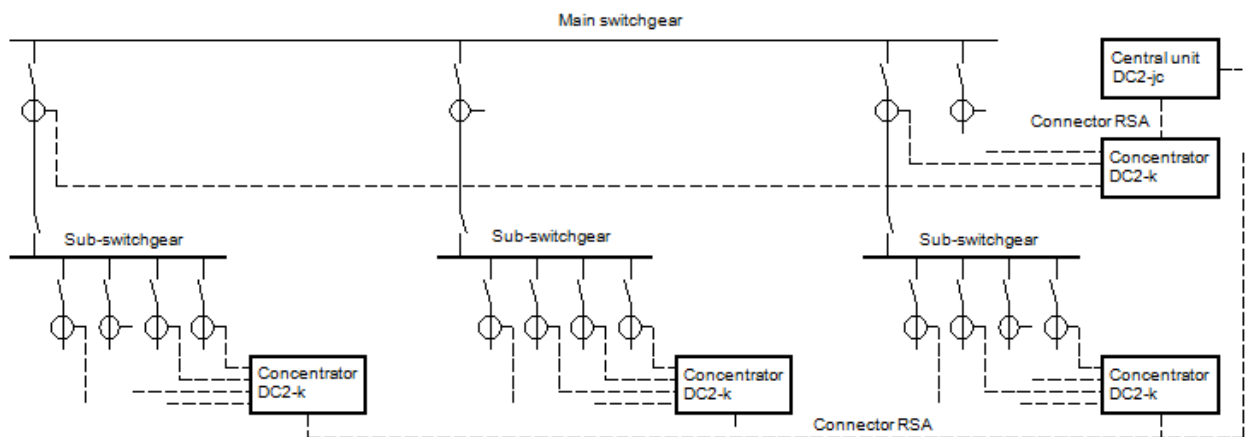

Figure 21. DCtest2 system in the main switchgear and sub-switchgears – variant 2.

Parameter:	Place of reading:
- insulation resistance of the entire network	- central unit in main switchgear, - concentrators in main switchgear,

	- concentrators in sub-switchgears,
- insulation resistance of outgoing of main switchgear	- central unit in main switchgear, - concentrators in main switchgear,
- insulation resistance of outgoing of sub-switchgear	- central unit in main switchgear, - concentrators in sub-switchgear,

Variant 3:

The central unit and concentrators are installed in the main switchgear.

The concentrators are installed in sub-switchgears (in the version with voltage measurement, measuring the generator voltage).

The economical variant is used when a large number of sub-switchgears located at a significant distance are supplied from the main switchgear – e.g.: the supply of kiosks on the power node.

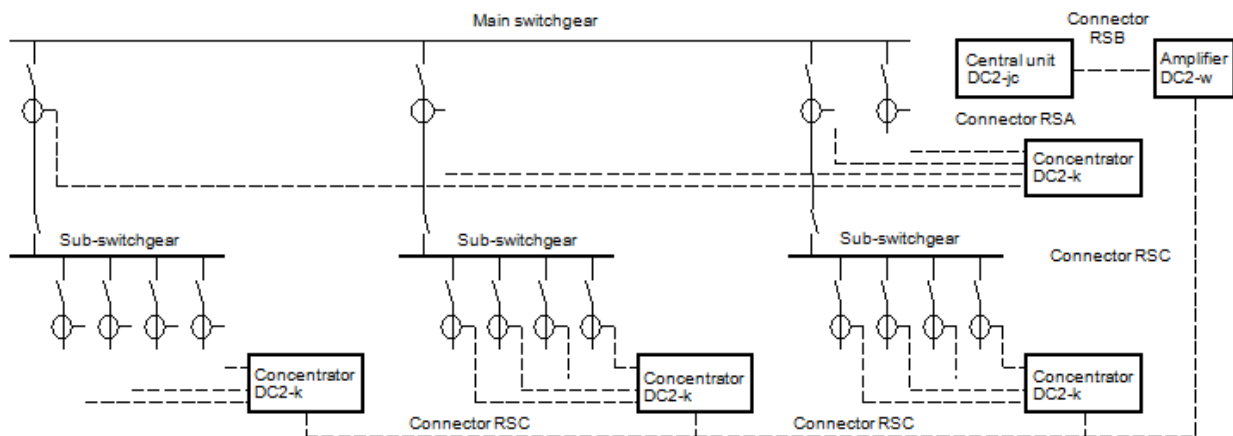

Figure 22. DCtest2 system in the main switchgear and sub-switchgears – variant 3.

Parameter:	Place of reading:
- insulation resistance of the entire network	- central unit in main switchgear, - concentrators in main switchgear,
- insulation resistance of outgoing of main switchgear	- central unit in main switchgear, - concentrators in main switchgear,
- insulation resistance of outgoing of sub-switchgear	- concentrators in sub-switchgear,

The value of generator voltage can be read on the displays of concentrators in the version with voltage measurement.

System DCtest-2 in two-section switching station

An example of two central units in the two-section switchgear supplied from two batteries is presented in figure 23.

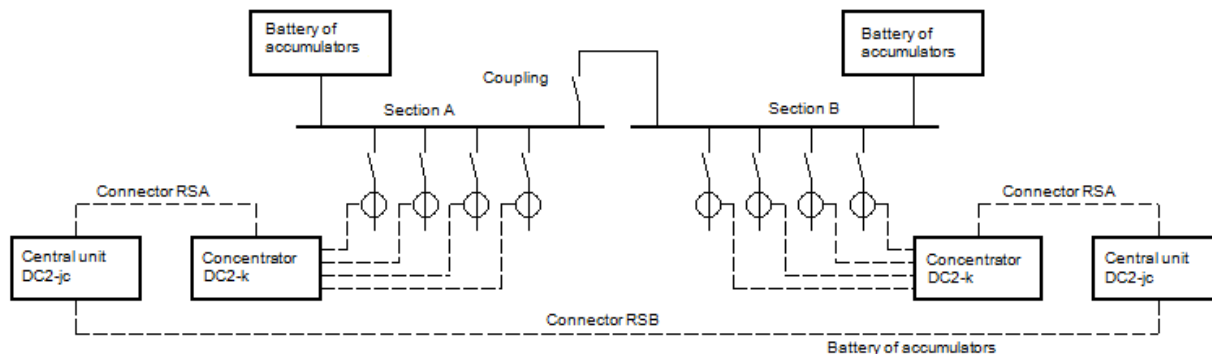

Figure 23. System DCtest-2 in two-section switching station

If both batteries work and a coupling is opened the central units work individually in independent direct current networks. The generators should operate in both units. If only one battery works both central units work in one direct current network. At that time one unit must be chosen as a master and the generator should work only in it. The operation of the should be programmed according to the table.

Configuration of direct current network	Central unit being a master	Central unit not being a master
both units work in one direct current network (1 battery works)	generator is activated (A4-A5 terminals opened) transmitter is activated (A4-A6 terminals opened)	generator is locked (A4-A5 terminals closed) transmitter is locked (A4-A6 terminals closed)
both units work in independent direct current networks (2 batteries work)	generator is activated (A4-A5 terminals opened) transmitter is activated (A4-A6 terminals opened)	generator is activated (A4-A5 terminals opened) transmitter is locked (A4-A6 terminals closed)

A change of configuration of the direct current network causes a necessity to change a way of operation of the system. The generator should be locked or activated in the central unit not being a master depending on a way of operation of the direct current network. A status of coupling connector position is information that can be utilized for an automatic setting of operation of the system (i.e. locking or activating of the generator).

If the coupling is closed it means that the entire network is supplied from one battery. If it is opened it means that there are two independent networks.

A signal from the coupling should be led to the central unit not being a master and employed it to lock the generator (closing of the coupling shall cause locking of the generator).

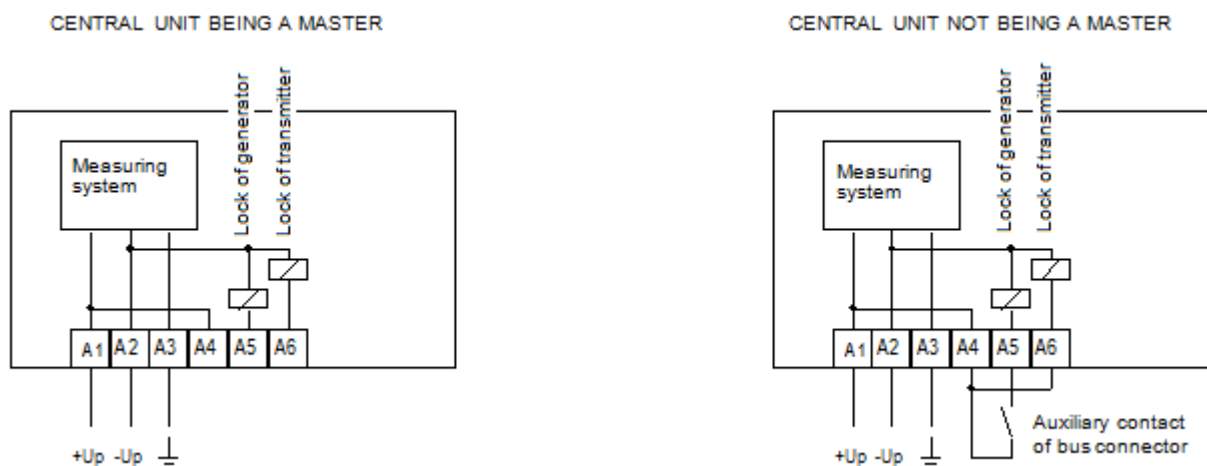

Figure 24. Diagram of locks of central units working in one network

3.3.4 DCtest2 system cooperation with other insulation condition control systems of direct current network

Other measuring systems, as a rule the systems using a voltmeter method, were employed to control the insulation condition of the direct current network in older switching stations. After the DCtest2 system is built in the previous voltmeter control system can be left but it is necessary to provide their concurrent operation. At that time the DCtest2 system works as a standard and the voltmeters are disconnected. To activate the voltmeter method it is necessary to break measurements performed by the DCtest2 system using for these purposes a contact of voltmeter switch to lock the generator (closing of A4-A5 terminals) in the central unit. If there is a possibility of operation of several units in one direct current network it is necessary to lock the generators in all the units simultaneously.

When the generator is locked an asterisk „*” appears on the liquid crystal display of the central unit at the place of indication of resistance of the entire network

4. Technical data

auxiliary supply voltage	auxiliary rated voltage U_{pn} (from direct current network): operating range of auxiliary voltage: admissible upper range value of auxiliary voltage: power consumption of central unit DC2-jc: power consumption of concentrator DC2-k:	selected from the range: 24..220 V DC 0,8...1,1 U_{pn} 1,3 U_{pn} (permanently) <10 W <6 W
generator	output voltage of impulse generator U_o (voltage induced to direct current network): semi-period time of generated impulses: Note: 1 s and 32 s semi-period times are utilized for test purposes internal resistance of generator: accuracy of measurement of test voltage induced in direct current network U_o :	<0,5 U_{pn} 1 ... 32 s 20 k Ω 10 %
indications of resistance of the entire network	range of indications of insulation resistance of the entire network: assigned error within range of up to 100 k Ω : assigned error within range of over 100 k Ω :	0...250 k Ω 10 % 15 %
measuring elements - thresholds	setting ranges: assigned error within range of up to 100 k Ω : assigned error within range of over 100 k Ω :	1...250 k Ω 10 % 15 %
measuring elements - times	setting ranges: assigned error:	10...2500s 10 %

indications of resistance of outgoing through measuring transformers	<p>range of indications of outgoing resistance: assigned error of measurement of current in outgoing: Note: accuracy of indications of outgoing resistance depends on accuracy of measurement of voltage U_0 (10%) and accuracy of measurement of current in (1 mA) Error of resistance measurement should be not higher than: $10 \% \pm \frac{1mA}{\frac{U_0}{R}} \times 100\%$</p>	<p>0...30 kΩ 1 mA</p>
indications of insulation condition of outgoing through portable locator	<p>range of indications of insulation condition, where: 0% - means full earth fault ($I > 5mA$) 100% - means the lack of earth fault ($I < 2mA$) assigned error of measurement of current: Note: accuracy of indications of insulation condition depends on accuracy of measurement of current (1 mA)</p>	<p>0%...100% 1 mA</p>
contact rated load	<p>current of continuous load: operational power for direct current at $T=40$ ms:</p>	<p>5 A 30 W</p>
electric insulation	electric strength of insulation	2 kV, 50 Hz, 1 min
environmental conditions	<p>rated range of ambient temperature: boundary value of extreme range of ambient temperature: relative humidity: atmospheric pressure:</p>	<p>-10...+55$^{\circ}$C -25 and +70$^{\circ}$C 45...75 % 86...106 kPa</p>
electromagnetic compatibility	<p>sharpness test class: maximum break time in supply with auxiliary voltage:</p>	<p>III 100 ms</p>
way of installation	<p>central unit DC2-jc: concentrator DC2-k: measuring transformers DC-I9, DC-I43: hanger for portable locator DC2-p:</p>	<p>surface-mounted or flush-mounted on bus TS-35 on bus TS-35 surface-mounted</p>

cases	Dimensions: Mass: protection degree:	acc. to item 3.2.2 acc. to item 3.2 IP40
-------	--	--

Remarks:

1. In case of disturbances (e.g. because of connection or disconnection of network fragment) a single appearance of indications going over the values given in the table is possible.
2. The manufacturer reserves a possibility to introduce modifications resulting from progress of science and technology.

5 Schedule of applied standards

During constructing and production of DCtest2 system there were applied standards which fulfilling provides the realization of assumed rules and safety means under condition that the user will follow the instructions and guidelines of installing and setting in motion and maintenance.

The DCtest2 system fulfils all standards specified in the following directives: low-voltage and electromagnetic compatibility, by accordance to the standards mentioned below:

Standard harmonised with low-voltage directive 73/23/EEC:

- PN-EN 60255-5:2002(U)
Electrical relays. Part 5: Insulation coordination for measuring relays and protection equipment; Requirements and tests

Standards harmonised with electromagnetic compatibility directive 89/336/EEC:

- PN-EN 50082-2:1997
Electromagnetic Compatibility (EMC). Generic Immunity Standard. Industrial Environment.
- PN-EN 50263:2002(U)
Electromagnetic compatibility (EMC). Product standard for measuring relays and protection equipment
– within the scope of below mentioned standards referred to this standard:
- PN-EN 61000-4-2:1999
Electromagnetic compatibility (EMC). Testing and measurement techniques. Electrostatic discharge immunity test. Basic EMC Publication
- PN-EN 61000-4-4:1999
Electromagnetic compatibility (EMC). Testing and measurement techniques. Electrical fast transient/burst immunity test. Basic EMC Publication
- PN-EN 61000-4-5:1998

Electromagnetic compatibility (EMC). Testing and measurement techniques. Surge immunity test

- PN-92/E-88608
Electrical relays. Electrical disturbance tests for measuring relays and protection equipment. 1 MHz burst immunity tests
- PN-EN 61000-4-12:1999
Electromagnetic Compatibility (EMC). Testing and Measurement Techniques. Oscillatory Waves Immunity Test - Basic EMC Publication
- PN-IEC 255-11:1994
Electrical relays. Decay and variable components of supplying auxiliary quantities of direct current measuring relays.

Moreover, the DCtest2 system equipment fulfil the requirements of the below-mentioned standards:

- PN-EN 60255-6:2000
Electrical relays. Measuring relays and protection equipment
- PN-EN 60255-21-1:1999
Electrical relays. Vibration, shock, bump and seismic tests on measuring relays and protection equipment. Vibration tests (sinusoidal)
- PN-EN 60255-21:2000
Electrical relays. Vibration, shock, bump and seismic tests on measuring relays and protection equipment. Shock and bump tests
- PN-EN 60255-21-3:1999
Electrical relays. Vibration, shock, bump and seismic tests on measuring relays and protection equipment. Seismic tests
- ENV 50204:1995
Electromagnetic compatibility. Radiated immunity from digital radio telephones

6 Data on completeness

The complete delivery for a recipient includes:

- DCtest2 system equipment (according to the order),
- Set of plug connectors,
- DCtest2 Operating Manual,
- Routine test report,
- Guarantee certificate.

7 Installation

7.1 General information

Before the first connection to the voltage the devices should spend at least two hours in a room where it is going to be installed in order to compensate the level of temperatures and to avoid moisturising.

The DCtest2 system should operate in conditions described in the technical data

7.2 External connections

The central unit is adapted to be surface-mounted or flush-mounted (depending on the version of the case). The measuring transformers are adapted to be mounted on the bus TS-35.

The individual devices should be connected according to the electric diagram. The external connections are delivered through disconnectable connectors of WAGO type and through DB9 drawer connectors.

The cases of some versions of central units require to connect he earth.

7.2.1 Connection of central unit

The central unit is equipped with the following connectors:

- WAGO – marked as “A” and “B” to connect signals at the level of voltage of controlled network, e.g. 220 V DC,
- DB9 drawer connector - RS485: RSA/1 and RSA/2 to communicate with measuring transformers, RSB/1 and RSB/2 to communicate with other units working in the network and with a portable locator, and to connect with an amplifier
- WAGO - marked as “RS485” and RJ45 - marked as “Ethernet” to connect with the Supervision and Control System,

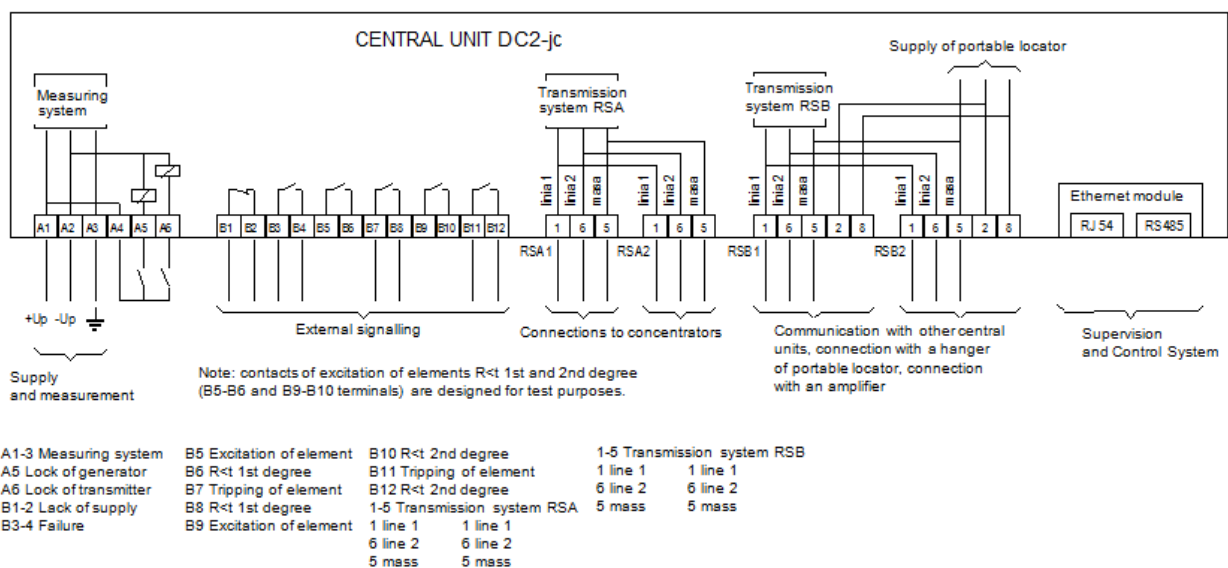

Figure 25. Diagram of external connections of central unit.

The central unit is supplied by DC voltage of controlled network. It is utilized for supplying electronic systems as well as for measuring purposes. With regard for the requirements of the measuring system the ground potential should be also brought to the central unit.

The central unit has 2 digital inputs brought to the A5 and A6 terminals utilized for locking the generator and transmitter. In order to lock the generator it is necessary to close the A4-A5 terminals and the A4-A6 terminals of the transmitter of the central unit. The locking of the generator and transmitter is utilized during the cooperation two or more central units with each other.

The central unit has 6 digital outputs utilized for external signalling. Depending on the number of signals it is recommended to send following information to the "Central Signalling":

number of signals to "Central Signalling"	Numbers of brought-out terminals (connected in parallel)
1- failure or reduction of insulation resistance	1-3, 3-4, 11-12
2- failure, disturbance - reduction of insulation resistance	1-2, 3-4, 11-12
3- failure - reduction of insulation resistance 1st degree - reduction of insulation resistance 2nd degree	1-2, 3-4, 7-8, 11-12
4- failure of supply - failure, disturbance - reduction of insulation resistance 1st degree - reduction of insulation resistance 2nd degree	1-2, 3-4, 7-8, 11-12

An LY-type conductor of 0,5...1,5 mm² cross-section is recommended to utilize for the connections of WAGO connectors.

A way of connection of communication connectors of the central unit with the other devices of the DCtest2 system is presented in item 7.3.

7.2.2 Connection of measuring transformers

The measuring transformers are elements measuring the distribution of test current in individual outgoing. The transformer has an opening through which the conductors of controlled primary circuit (the conductors of determined outgoing of the direct current network) should be brought. The currents of working load brought through the transformer window must be compensated. The measuring transformer should include all the conductors of determined outgoing:

- positive and negative conductor outgoing supply,
- conductors of signalling of flashing light and continuous light,
- other conductors connected galvanically with the above-mentioned ones.

An LY-type conductor of 0,5...1,5 mm² cross-section is recommended to utilize for the connections with the concentrator.

7.2.3 Connection of concentrator

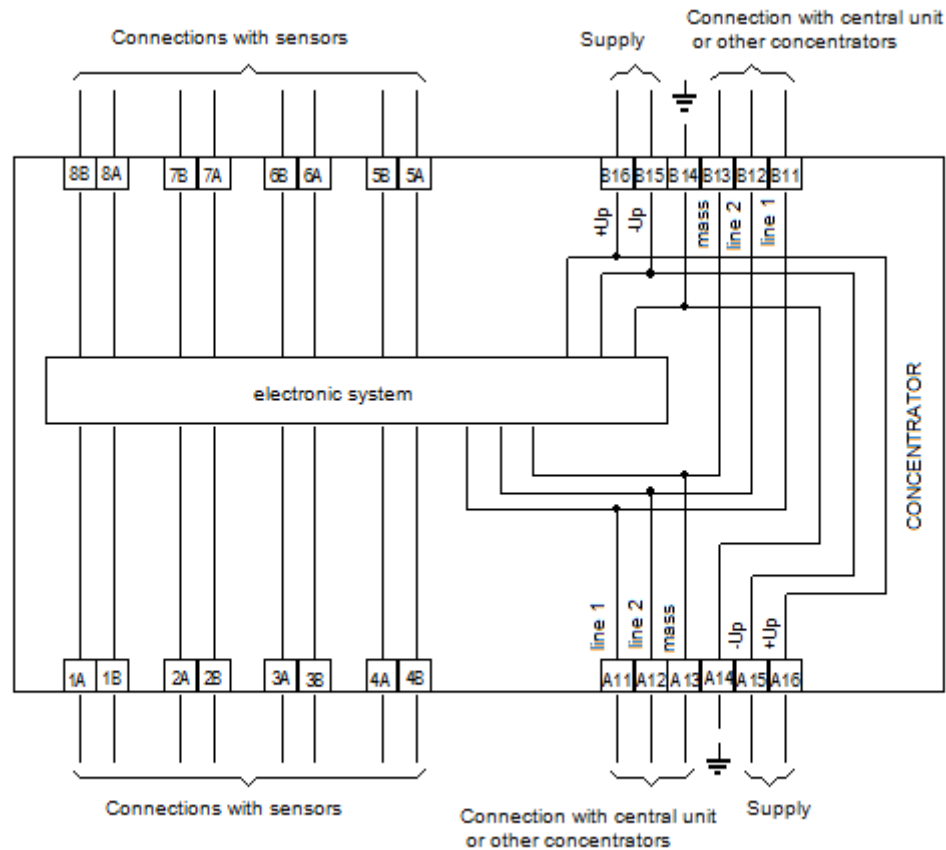

Figure 26. Diagram of external connections of concentrator.

The external connections are delivered through disconnectable WAGO connectors. The connectors for the supply and communication are of double type. They have letter designations of "A" and "B". To facilitate the installation of external circuits the connectors are brought out from the top and from the bottom of the concentrator case. The next terminals of both connectors are bridged.

An LY-type conductor of 0,5...1,5 mm² cross-section is recommended to utilize for the connections. For the communication connections, if their length is larger than 50 m, it is necessary to utilize two-strand shielded cable (the shield should be connected on both sides to the "mass" terminal, do not earth), and if their length is smaller, three-strand unshielded cables (bunches) can be used.

7.2.4 Connection of portable locator

The portable locator completes an earth fault location stationary system. It is employed to measure ground currents in the outgoings in which stationary measuring transformers are not installed. The portable locator consists of current pincers and a hanger. The pincers are supplied by LR44

batteries. The hanger should be built in near the central unit and connected permanently to an RSB input of the central unit. It is sufficient to use one portable locator in the entire network. If several central units, connected by the RSB network, operate in a determined object, the hanger can be built in at any unit.

7.3 Communication connections

Two independent communication systems employing RS485 connectors are used in the system. One of them (called RSA) is utilized for conveying information within the central unit and concentrators related to it. The task of the second system (called RSB) is to ensure the communication between the central units.

7.3.1 Connections between central unit and measuring transformers (RSA)

A concept of operation of RSA transmission system designed for conveying information within the central unit (i.e. the main microprocessor, voltmeter and ammeter as well as generator) and concentrators is presented in figure 27.

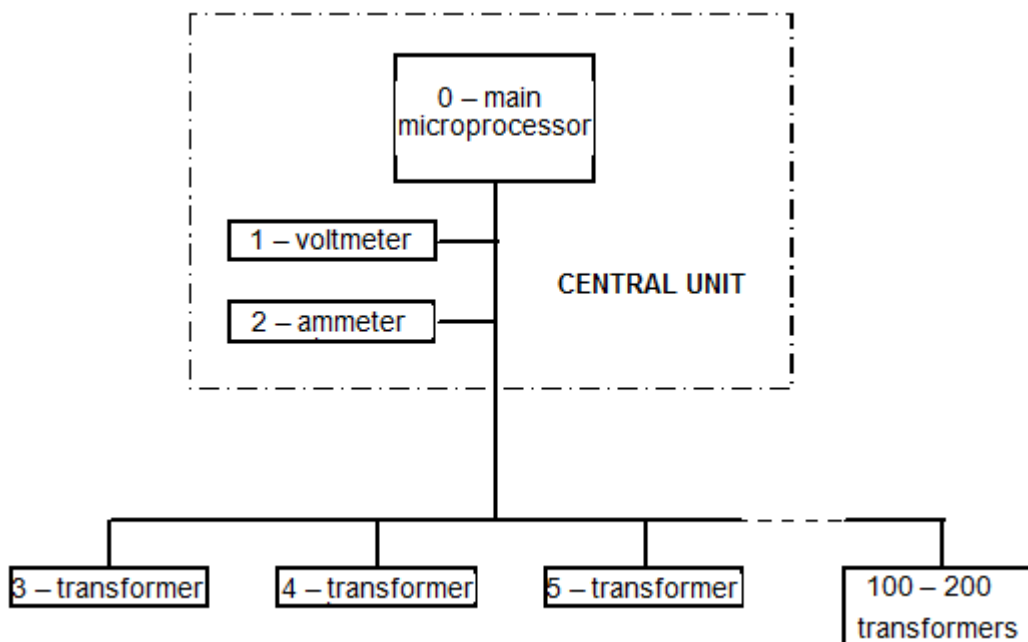

Figure 27. Principle of operation of RSA transmission system.

It is necessary to notice that all the elements of the system are connected in parallel. The communication is controlled by the main microprocessor which is a master in this network. The transmission runs in stages that recur cyclically.

The main microprocessor conveys information on a voltage value to all the devices (this value was measured by a voltmeter in a previous cycle and conveyed to the main microprocessor) and it

transmits impulses synchronizing an operation of the generator and synchronizing the measurements.

All the devices process received information and prepare feedback to the main processor. Feedback is a voltage value measured by the voltmeter and resistance value in outgoings calculated by the concentrators.

The main microprocessor inquires subsequent devices and they transmit feedback in a determined order.

The main microprocessor analyses received information and on its basis updates results shown on the LCD display and decides excitation of signalling.

The transmission of information from the main microprocessor to the concentrators and reverse communication must be carried out in a proper order. Each of devices has a coded identification number according to which it is identified.

The numbers are as follows:

0 - main microprocessor,

1 – voltmeter,

2 – ammeter

3 – 100 (200) - individual measuring transformers,

All the devices installed in the DCtest2 system are connected by means of the network of conductors utilized for communication. The central unit is equipped with WAGO connectors and DB9 drawer connectors, concentrators and battery controllers are equipped with WAGO connectors.

An exemplary diagram of connections between the central unit, concentrators and measuring transformers is presented in figure 28.

The following connections should be executed:

- To connect terminals utilized for communication marked as “line1”, “line2”, “mass” between the central unit and concentrators. The terminals of the same name should be connected in parallel in all the devices. For the connections it is necessary to utilize two-strand shielded cable (the shield should be connected on both sides to the “mass” terminal, do not earth), and if the length of connections is smaller than 50 m, three-strand unshielded cables (bunches) can be used.
- Measuring transformers should be connected with concentrators by means of two-strand bunches made of LY-type conductor of 0,5...1,5 mm² cross-section.

The DC2-k concentrators are equipped with double connectors for the supply and communication marked as “A” and “B”; to facilitate the installation the connectors are brought out from the top and from the bottom of the concentrator case. The next terminals of both connectors are bridged.

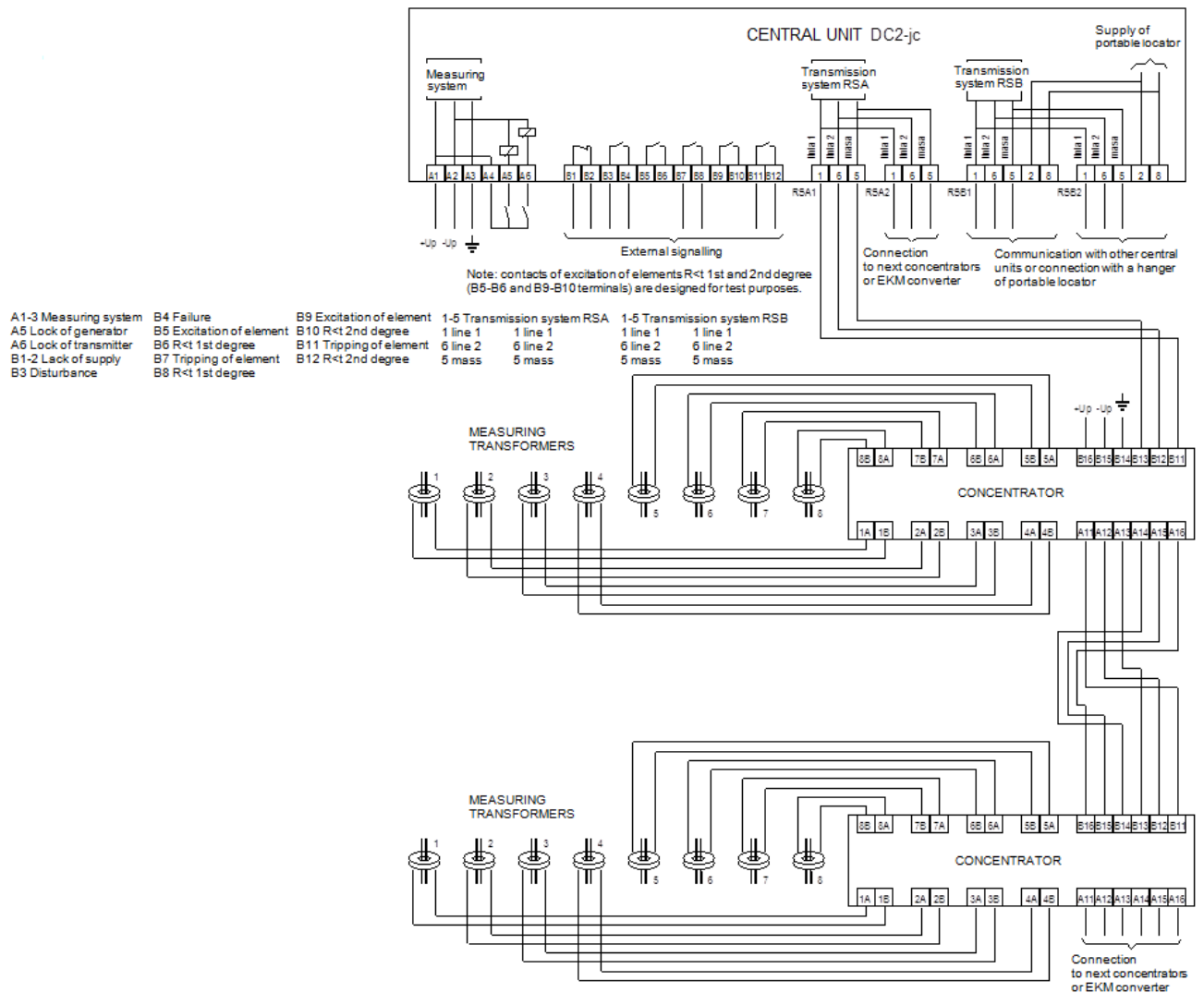

Figure 28. Exemplary diagram of connections between central unit, concentrators and measuring transformers.

7.3.2 Connections between central units

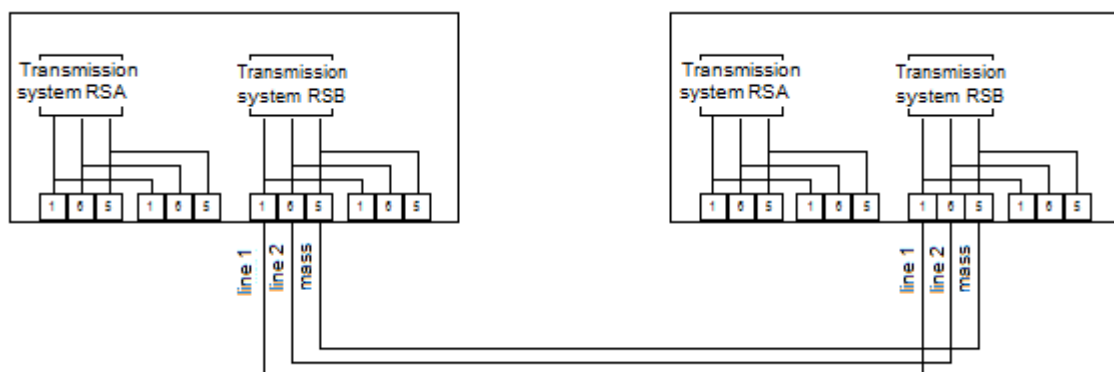

Figure 29. Exemplary diagram of connections between central units

The RSB transmission system is utilized for the connections between the central units. The transmission of the data is carried out in one direction. The data are transmitted by this unit that acts as a master in the system. In the other ones, the transmitters must be locked by closing the A4-A6 input terminals of the central unit. When active transmitters are left in several central units the transmitters are locked automatically in the accidental units.

For the connections it is necessary to utilize two-strand shielded cable (the shield should be connected on both sides to the “mass” terminal, do not earth), and if the length of connections is smaller than 50 m, three-strand unshielded cables (bunches) can be used.

A diagram of connections of two central units is presented in figure 29. If there is a need to communicate between a larger number of the units the connections should be configured individually depending on existing conditions.

The total length of the transmission network can be up to 1000 m.

7.3.3 Connection between central unit and portable locator

The portable locator consists of current pincers and a hanger. The hanger should be built in near the central unit and connected permanently to an RSB input of the central unit. It is sufficient to use one portable locator in the entire network.

If several central units, connected by the RSB network, operate in a determined object, the hanger can be built in at any unit.

7.3.4 Connection with Supervision and Control System

The central unit is equipped with an Ethernet Module. It ensures a remote reading of current condition of the device and makes the data accessible to the Supervision and Control System

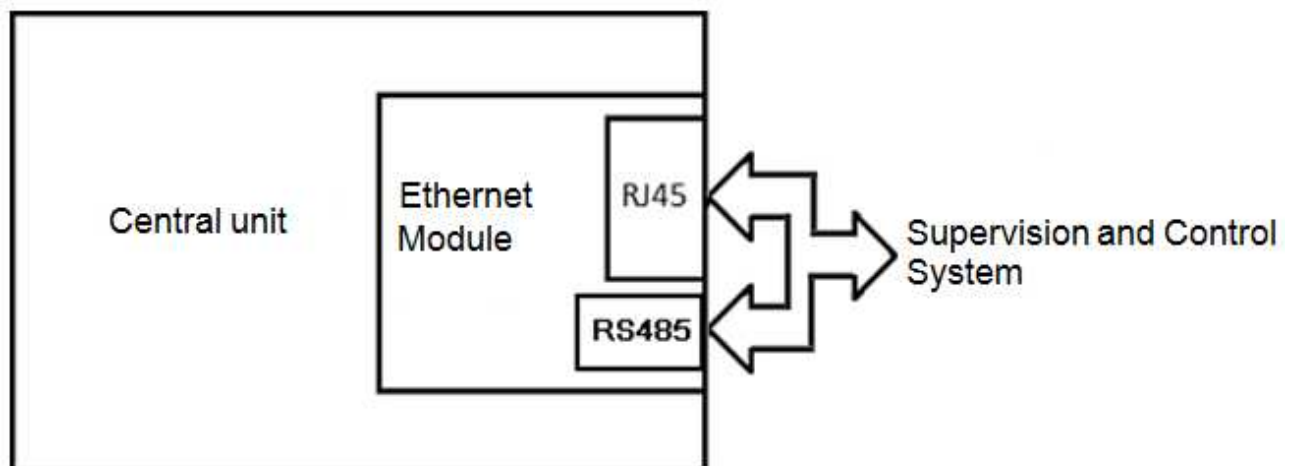

Figure 30. Ethernet Module built inside Central Unit

1. Modbus

The Ethernet Module makes the data accessible by the agency of Modbus TCP and RTU protocol. The Modbus server is activated on the TCP port with the number 502. The following information can be read:

- current condition of device and setpoint,
- current condition of outgoings (resistances in individual outgoings, failures, names of outgoings),
- list of registered events (time and date of occurrence and event code),
- condition of device and outgoings at the moment of event occurrence.

A “Read Holding Registers” (0x03) function of Modbus protocol is utilized to read the data. The registers can be only read. A detailed list of registers of Modbus protocol is presented in the below table (an address is given in a decimal form!):

Address	Type	Name	Description
0000	unsigned	Status	Bit 2: the lack of communication with DCtest2
		N	Number of present outgoings
0001	unsigned	-	-
	unsigned	Us	Value of voltage induced in direct current network
0002	unsigned	GLed	Condition of green diodes
	unsigned	RLed	Condition of red diodes
0003	unsigned	Thr1	Resistance of excitation of measuring element R<t 1st degree
	unsigned	Thr2	Resistance of excitation of measuring element R<t 2 degree

0500	unsigned	Num	number of registered events
0501	unsigned	Last	Number of last event
0502+4n	unsigned	Code	Event code n (n = 0..Num-1)
0503+4n	unsigned	Year	Year
		Month	Month
0504+4n	unsigned	Day	Day
		Hour	Hour

0505+4n	unsigned	Min	Minute
		Sec	Second
1000	unsigned	Rs	Network resistance
	unsigned	RsStatus	Bit 5: 1 – the lack of communication with ammeter Bit 6: 1 – resistance >255, 0 – resistance <255 Bit 7: 1 – ammeter disturbed, 0 – correct indication
1001	signed	RsName[0]	Name of ammeter
	signed	RsName[1]	
1002	signed	RsName[2]	
	signed	RsName[3]	
1003	signed	RsName[4]	
	signed	RsName[5]	Mark NULL
1004+4n	unsigned	RN	Insulation resistance of outgoing n (n = 0..197)
	unsigned	RStatus	Bit 5: 1 – the lack of communication with outgoing Bit 6: 1 – resistance >255, 0 - resistance <255 Bit 7: 1 – ammeter disturbed, 0 – correct indication
1005+4n	signed	RName[0]	Name of outgoing n
	signed	RName[1]	
1006+4n	signed	RName[2]	
	signed	RName[3]	
1007+4n	signed	RName[4]	
	signed	RName[5]	Mark NULL
2000 + i*2000 - measurements registered for the event i, i = 0..Num-1			
Description of registers analogically as for current measurements (from the address 0000 with omission of the table of events beginning from the register of the address 500)			

The register of the address 0001 (GLed and RLed bytes) stores information on a condition of the diodes located on the front panel of the Central Unit. The interpretation of these bytes is as follows:

Bit number	GLed	RLed	Description
1	1	1	Disturbance of measurement
	0	1	Damage of sensor
2	1	1	Excitation of element R<t 1st degree
3	0	1	Tripping of element R<t 1st degree
4	1	1	Excitation of element R<t 2nd degree
5	0	1	Tripping of element R<t 2nd degree

The bit 7 and bit 0 of RLed byte code the mark of the line shorted to ground according to the following rule:

Bit 7	Bit 0	
0	0	It is impossible to determine which line is shorted to ground
0	1	
1	0	Negative pole shorted to ground
1	1	Positive pole shorted to ground

2. IEC103

The Ethernet Module makes the data accessible by the agency of IEC103 protocol. The selection between the Modbus and IEC103 protocol is made by the agency of the device website. The ASDU address should be set such as a physical address of the device, configurable by means of website.

The following information can be read:

- current condition of outgoings (resistances in individual outgoings, failures, names of outgoings),
- events at the moment of occurrence (time and date of occurrence and event code),

Information in monitoring direction:

Function No.	Information No.	Description	Type of message	Reason of transmission
0	0	Voltage of network	9	2
1	0	Ammeter disturbed	1	1
2	0	Resistance of network > 255 kΩ	1	1
3	0	Resistance of network	9	2
4	0 .. n – 1	Ammeter of outgoing n disturbed	1	1
5	0 .. n – 1	Resistance of outgoing n > 255 kΩ	1	1
6	0 .. n – 1	Resistance of outgoing n	9	2

7	0	Disturbance	1	1
7	1	Damage	1	1
7	2	Excitation of element 1st degree	1	1
7	3	Tripping of element 1st degree	1	1
7	4	Excitation of element 2nd degree	1	1
7	5	Tripping of element 2nd degree	1	1
20	0	Lack of communication with DCtest2 system	1	1

3. Events

The Ethernet module controls a condition of the DCtest2 device permanently and generate events in strictly determined cases. The following information is registered for every generated event: time, date, code of event, condition of device and parameters of outgoings. The events are registered in a circular buffer able to store up to 30 events.

Name	Status	Code of event	Priority
Disturbance of measurement	There is	31	3
Disturbance of measurement	There is not	32	5
Damage	There is	33	3
Damage	There is not	34	5
Excitation of element R<t 1st degree	There is	11	2
Excitation of element R<t 1st degree	There is not	12	5
Tripping of element R<t 1st degree	There is	13	1
Tripping of element R<t 1st degree	There is not	14	5
Excitation of element R<t 2nd degree	There is	21	2
Excitation of element R<t 2nd degree	There is not	22	5
Tripping of element R<t 2nd degree	There is	23	1
Tripping of element R<t 2nd degree	There is not	24	5

4. Visualisation by means of website

The Ethernet module is equipped with a website server that makes possible to display a device website on any computer. An access to it can be obtained entering an IP address of Ethernet module in the address field of web browser.

The website of the device is utilized for visualisation of current measurements, registered events, condition of device. It makes a basic configuration and review of the service data possible as well.

To display the website properly they are require the following:

- virtual machine JAVA from version 6.0
- web browser with switched-on JavaScript service.

The website is opened properly in the following web browsers: Firefox, Opera, Chrome, Internet Explorer in version 7 or higher

a) Navigation menu

The menu consists of three tabs (DC-TEST, Configuration, Statistics) and general information on the Ethernet module (figure 31), such as: operation time from device activation, name, firmware

version, condition of module supporting battery, clock, network setting and temperature of Ethernet module processor. At the bottom of the menu there is an area of connections informing the user of current condition of connections between the website and module.



Figure 31. Main menu of device website.

b) DC-TEST

The DC-TEST tab together with the navigation menu are presented in figure 32.

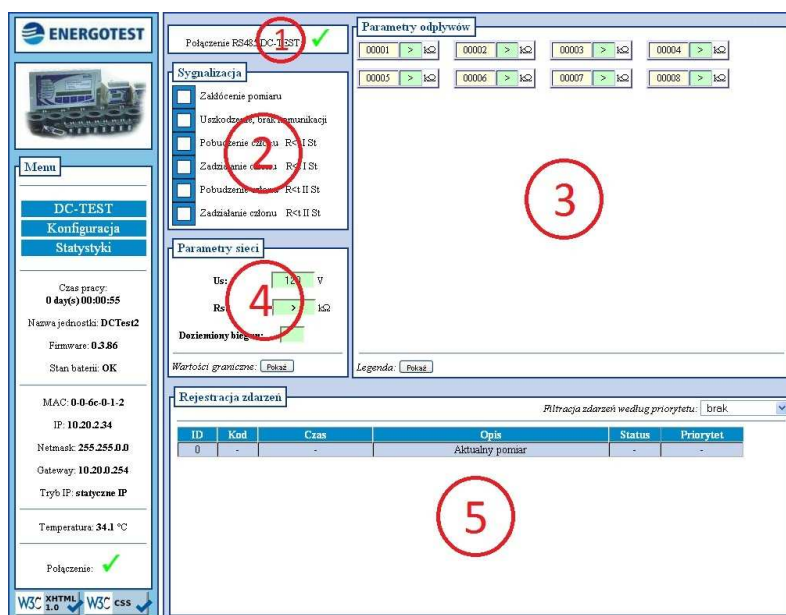

Figure 32. Device website – DC-TEST tab

The areas marked by figures from 1 to 5 have the following meaning:

- 1 – informs the user of connection condition of Ethernet module with the DCtest2 device,
- 2 – is a reflection of front panel diodes of the DCtest2 device but a “damage” diode signalling disturbance or damage is divided into two diodes,
- 3 – is a visualisation of monitored outgoings. The following information is available:
 - name of outgoing
 - outgoing insulation resistance or symbol standing for disturbance or damage.
 A legend clarifying the meanings for a determined outgoing is displayed after pushing the button “Present” at the bottom of the area what is shown in figure 33 by means of the number 7,
- 4 – is a visualisation of parameters of the direct current network. The following information is available:
 - U_s - value of voltage induced in the direct current network
 - R_s - resistance of network (symbols according to the legend for outgoings)
 - pole shorted to ground – information on the fact which pole of the network is shorted to ground.

The information on set boundary values of can be obtained after pushing the button “Present” at the bottom of the area what is shown in figure 33 by means of the number 6,

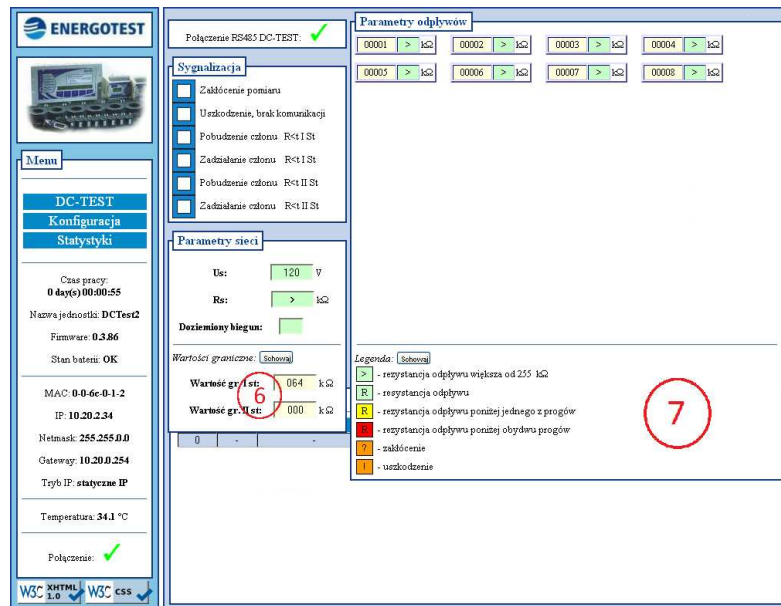

Figure 33. Device website – DC-TEST tab

- 5 – includes a table of registered events. Each of them is described by a code of event, time of occurrence, status (“there is” or “there is not”) and priority. After pushing any line in the table of events, parameters of the network and outgoing assume values registered at the moment of event occurrence. Any time it is possible to return to current measurements by pushing a “current measurement” line. The table can be sorted according to the priorities of registered events. A drop-down menu for this purpose is marked in figure 34 by the number 8.

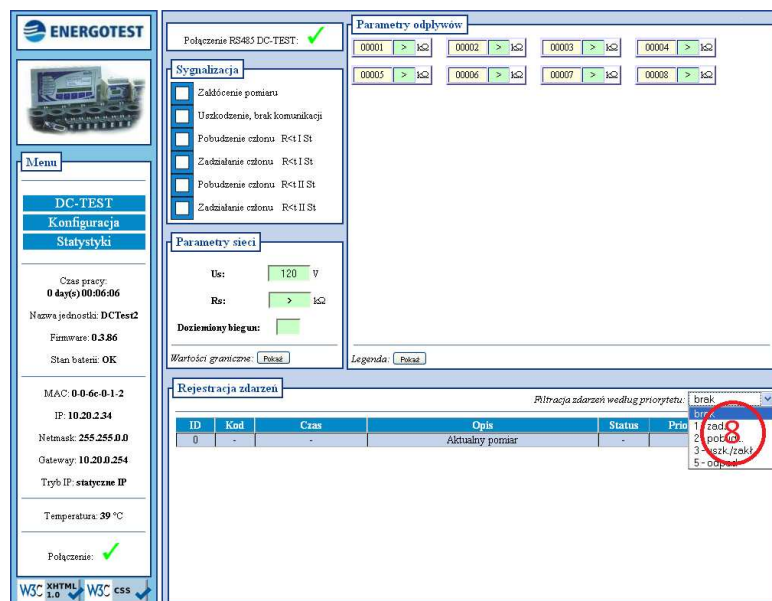

Figure 34. Device website – DC-TEST tab

c) Configuration

A configuration tab is presented in figure 35. The areas marked by the numbers 9 and 10 have the following meaning:

- 9 – makes possible to perform a configuration of transmission parameters of RS-485 serial port,
- 10 – makes possible to read and set the date and time in the RTC internal clock.

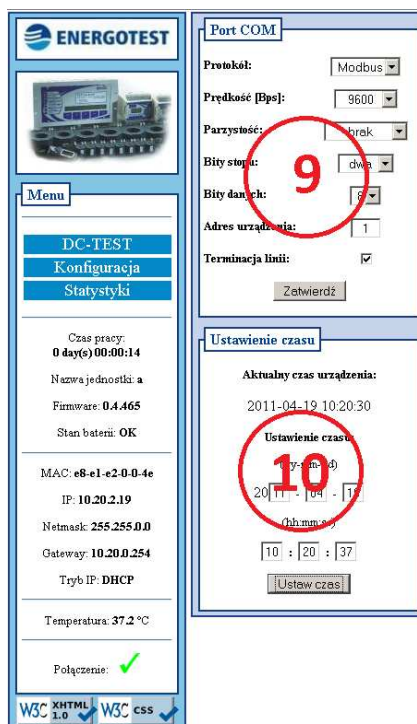

Figure 35. Device website – configuration tab

d) Statistics

The tab is presented in figure 36. Three areas, marked by the numbers from 11 to 13 were allocated:

- 11 – delivers the service data concerning a communication between the module and DCtest2 device,
- 12 – delivers the service data concerning a transmission of the data by Modbus TCP protocol,
- 13 – delivers the service data concerning a transmission through the RS485 serial port.

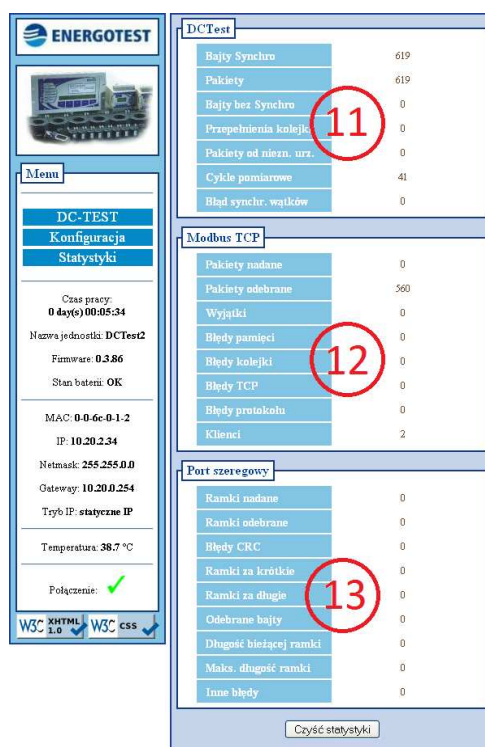

Figure 36. Device website – statistics tab

8 Activation

8.1 General information

After the installation of the DCtest2 system it is necessary to perform its activation according to the generally accepted rules concerning protection, automation and control devices.

It includes the following actions:

- verification of conformity of the design to the documentation of the system paying a special attention to:
 - rated value of supplying voltages and their polarity,
 - correctness of applied protection devices of voltage circuits (rated values of fuse elements or rated currents and characteristics of trippers),
 - verification of correctness of installation,
 - verification of continuity of earthing circuits,
 - setting of code numbers of individual concentrators
 - setting of the number of measuring transformers connected to a determined concentrator,
 - setting of thresholds of signalling operation,
 - setting of delay of time elements,
 - setting of time of semi-period of generated impulses,
- check measurements of ground resistance of the entire network

-
- check measurements of ground resistance of individual outgoing,
 - execution of functional tests.

8.2 Parameters set in DCtest2 system

DC2-jc central unit.

- The number of devices in the network – the number of devices cooperating with a main microprocessor.

This number includes a voltmeter and an ammeter, and measuring transformers. Practically, it is necessary to enter a number of transformers increased by 2 (i.e. by a voltmeter and an ammeter).

- Threshold of excitation of element 1 – excitation resistance of measuring element $R < t$ 1st degree.
- Delay of tripping 1 – time delay of tripping of measuring element $R < t$ 1st degree.
- Threshold of excitation of element 2 - excitation resistance of measuring element $R < t$ 2nd degree.
- Delay of tripping 2 – time delay of tripping of measuring element $R < t$ 2nd degree.
- Half of generator period – generator operation frequency; time of semi-period of generated impulses (s) is set.
- Device No. 002 – an ammeter measuring the current of the entire network is coded under this number; it is necessary to enter the name that is to be displayed over the resistance value of the entire network (e.g. NETWORK).
- Devices Nos. 003...100(200) – individual measuring transformers coded under these numbers; they should be named according to the names of outgoing in which they are built in.

DC2-k concentrators.

- Device number– code number of the first transformer connected to a determined concentrator. The numeration should be started from 003 (numbers 000, 001 and 002, there are a processor, voltmeter and ammeter in the central unit).

- Number of devices – number of measuring transformers connected to a determined concentrator.

Note: A number of the previous concentrator, increased by the number of measuring transformers connected to the previous concentrator, should be entered as a “device number” of the subsequent concentrator. The individual transformers must be numbered in sequence – there cannot be breaks in the numeration.

8.3 Functions of push-buttons on front panel

DC2-jc central unit.

There are 5 push buttons on the front panel. They fulfil the following functions in the basic mode:

MENU – held for 2 seconds causes a transition to the setpoint mode,

< and > - change the page number of displayed outgoing,

MEM – change of display mode of sequence of outgoing into a sequence according to the resistance values from the lowest to the highest (this is a basic mode marked as “< >”) or according to the increasing numbers of addresses of individual measuring transformers (marked as “No.”).

ESC – display transition to the basic display mode of sequence of outgoing.

DC2-k concentrator.

There are 4 push buttons on the front panel. They fulfil the following functions in the basic mode:

MENU - held for 2 seconds causes a transition to the setpoint mode,

< and > - change the page number of displayed outgoing and a page of parameters of the entire network

MEM – it is inactive in this mode.

8.4 Way of entering setpoints

DC2-jc central unit.

The push buttons fulfil the following functions (each of push buttons realizes two functions) after switching to the setpoint mode

MENU – entry to the setpoint mode and selection of currently changed mark when entering the names of outgoing,

< - selection of parameter and change of parameter value down.

> - selection of parameter and change of parameter value up.

MEM – transition to the change of value of selected parameters and confirmation of newly entered value,

ESC – resignation of newly entered value and exit from the setpoint mode.

To change hitherto setpoints it is necessary:

1. To push the "MENU" push button and to hold it for about 2 seconds.
2. To select a parameter or name of outgoing by means of "<" and ">" push buttons. The display will show the names of individual parameters and their current values in sequence. The numbers and names of individual outgoing will be presented at the end of the list.
3. To switch to the option of setpoint change by means of "MEM" push button. The mark "<>" will change into "*".
4. To select a proper value or proper mark in the name of outgoing by means of "<" and ">" push buttons. The mark in the name of outgoing is selected by means of "MENU" push button.

5. To confirm the change of setpoint by means of "MENU" push button. The mark "*" will change into "<>". You can resign the entry of the change by means of "ESC" push button. It is equivalent to the exit from the setpoint mode.
6. To make subsequent changes of setpoints according to items 2 ... 5.
7. To exit from the setpoint mode by means of "ESC" push button after entering all the changes. The display will show a message; "MEM" means memorizing the data, "ESC" means restoring the data from the memory. It is necessary to confirm the change of setpoints by means of "MEM" push button (to store new setpoints in the memory) or resign the change by means of "ESC" push button (to leave old setpoints in the memory).

Instead of the code numbers of individual measuring transformers it is necessary to give them the names of outgoings in which they are built. The name may consist of five marks – there can be capital letters, small letters, figures, punctuation marks and space. The procedure is described in items 2 ... 5.

If the descriptions of outgoings are to differ from each other only in subsequent numbers the auto-numeration can be employed for entering their names. Two first marks of the name are invariable (there can be capital letters, small letters, figures, punctuation marks, space) and they are given for all the outgoings identical. It is necessary to enter a three-figure number (only figures) as three last marks of the name. The auto-numeration can be started from any outgoing.

Example:

Device No.	Name of outgoing	
003	Ab001	- to enter Ab001 in the name of the device No. 003, then to push MEM and MENU simultaneously.
004	Ab002	
005	Ab003	
006	Ab004	
007	Ab005	
008	C 011	- to enter C_011 in the name of the device No. 008, then to push MEM and MENU simultaneously.
009	C 012	
010	C 013	
011	C 014	
012	C 015	
013	C 016	
014	C 017	
015	C 018	
016	D116	- to enter _D116 in the name of the device No. 016, then to push MEM and MENU simultaneously.
017	D117	
018	D118	
019	D119	
020	D120	

When the names are entered it is necessary to exit the setpoint mode as it is described in item 7.

DC2-k concentrators.

After switching to the setpoint mode the push buttons fulfil the following functions:

MENU – entry to the setpoint mode – number of devices, device No.,

< - change of set parameter value down.

> - change of set parameter value up.

MEM - confirmation of newly entered value and simultaneous exit from the setpoint mode.

To change hitherto setpoints it is necessary:

- 1- To push the "MENU" push button and to hold it for about 2 seconds – entry to the mode of setting of the number of devices.
- 2- To set the number of measuring transformers connected to the concentrator by means of "<" and ">" push buttons.
- 3- To push the "MENU" push button – transition in the setpoint mode to setting a device's number.
- 4- To set a device's number by means of "<" and ">" push buttons (a code number of the first measuring transformer connected to the concentrator).
- 5- When all the changes are entered it is necessary to push the "MEM" push button what will cause the confirmation of the entered data and simultaneous exit from the setpoint mode.

8.5 Location of earth fault

8.5.1 Location of earth fault in direct current network in which all outgoings are measured

The earth fault location method is presented using an example of the direct current network shown in figure 37.

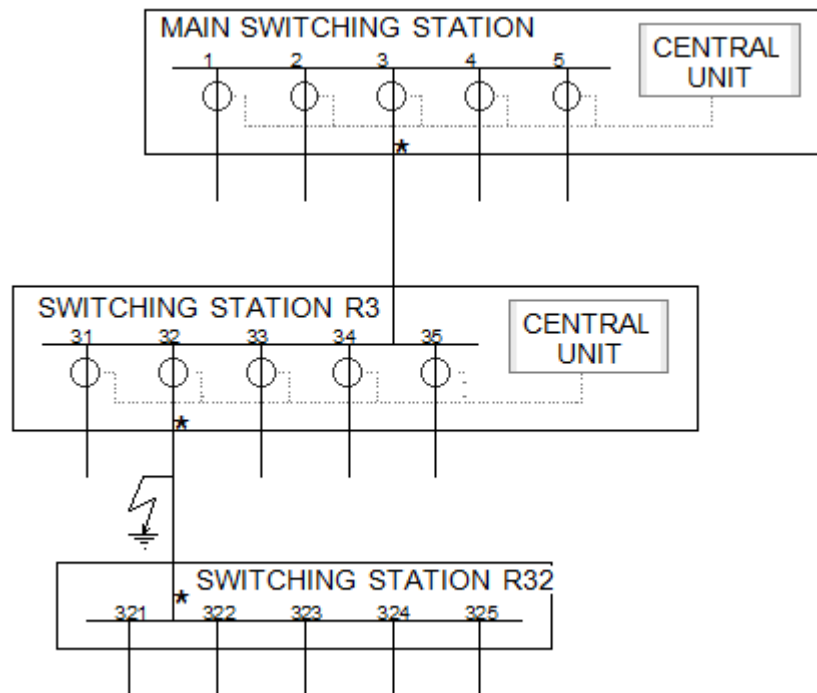

Figure 37. Location of earth fault in direct current network.

The insulation condition of the entire direct current network is controlled in the central unit installed in the main switching station. A measuring element $R < t$ controlling the insulation condition in case of resistance reduction below a set value signals an emergency condition.

First, it is necessary to check the indications on the display of the central unit installed in the main switching station. The locator identifies the earth fault in the outgoing No. 3 supplying the switching station R3.

Then, it is necessary to check the indications on the display of the central unit built in the switching station R3. The locator indicates the outgoing No. 32 supplying the switching station R32. The earth fault is in a cable supplying the switching station R32 or in the switching station itself.

8.5.2 Location of connections between circuits and connections between batteries

Irregularities making the operation of the network difficult include closing (connection) of like adjacent circuits supplied by various fuses. In such a case a disconnection of the outgoing does not deprive the consuming systems of voltage.

At present there is no device that automatically, without the personnel's interference, can detect closings (connections) between the circuits.

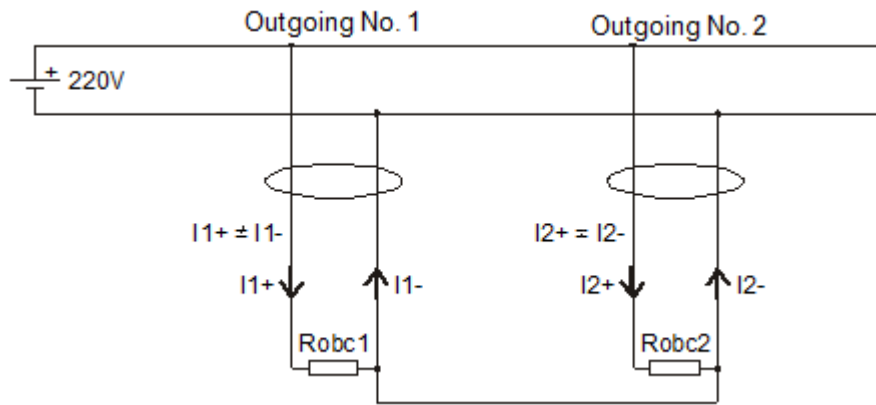
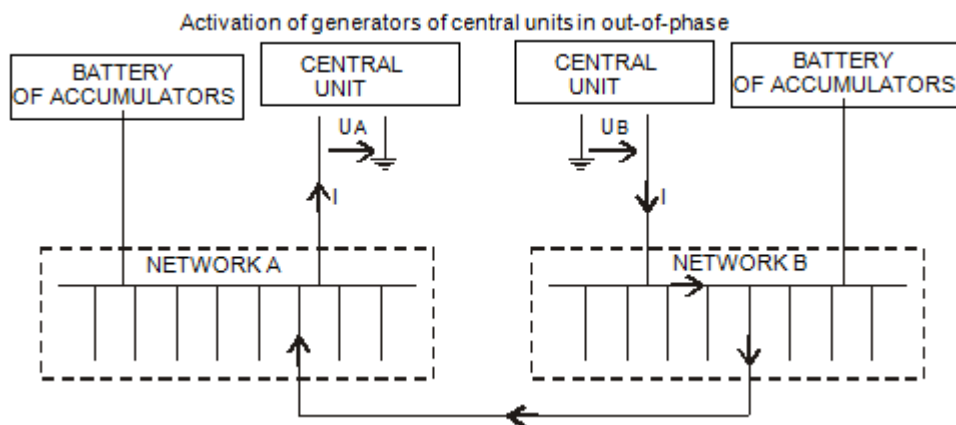

Figure 38. Closing (connection) between circuits.

A flow of work current between connected outgoing that overlaps on a measuring signal measured by the sensors is a basic symptom of such damage. This current, depending on its value, can disturb the measurement in such a degree that the sensor signals a disturbance in the outgoing. Furthermore, such a connection can be detected during the execution of control earth faults. At that time, the measuring currents are distributed between two circuits and the results of measurements are not compliant with anticipated ones. The detection of such connections depends on many factors, and in particular, on the resistance at the place of connection, what impacts the value of fault currents. The personnel's experience helping in a correct interpretation of the DCtest2 system indications is very important as well.

Closing (connection) between the circuits supplied from various batteries built in a determined object is another serious fault appearing relatively often in the operation of the direct current network. It results in the transfer of all the disturbances between the batteries, and furthermore, the occurrence of double voltage of the batteries between the conductors in case when the opposite poles are connected. The DCtest2 system makes the detection of such a connection possible. Two detection methods of such connections are presented diagrammatically in figure 39.



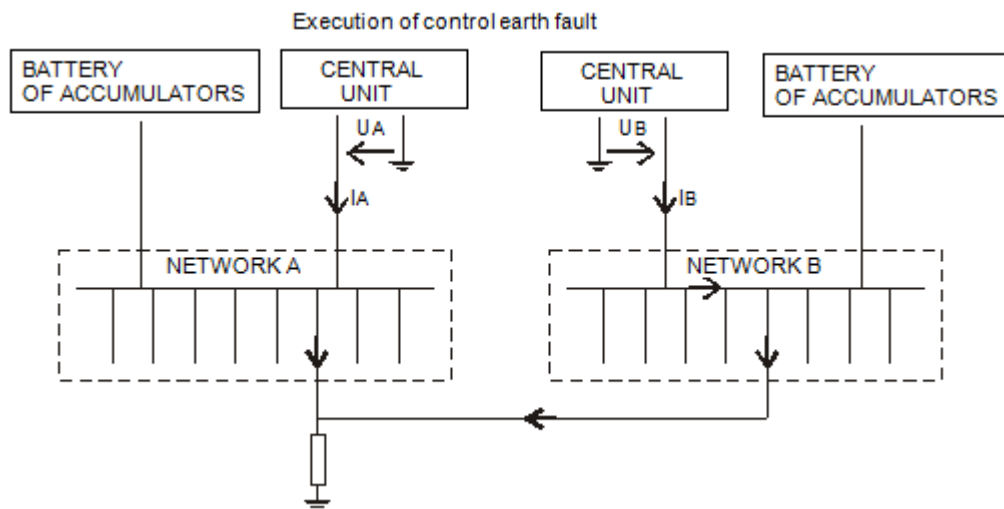

Figure 39. Methods of detection and location of connections between batteries.

To detect a connection between separately operating direct current networks it is necessary to change a mode of generating in an out-of-phase in one of central units. For this purpose it is necessary to push a scrolling push button “<” and holding it to push the second scrolling push button “>”. Additionally, the letter “I” (inversion) informing of inverted phase appears on the LCD display in place where a way of outgoing display sequence (according to <> or according to No.) is shown. If there is a connection between the circuits of both independent networks, the displays of central units present the outgoings in which this connection occurs – both the units show the resistances of the network $0k\Omega$, in the outgoings in which the connection takes place; the indications are $0k\Omega$ as well.

When the outgoings in which a connection between separate networks exists are located, the generators of the central units should be synchronized in the phase. For this purpose, in the central unit in which the phase is inverted it is necessary to push the scrolling push button “<” and holding it to push the second scrolling push button “>”. The “I” letter informing of inverted phase disappears from the LCD display and the “Operation of the system” control lamps will blink synchronically.

The other method consists in performing a control earth fault in the network of one battery. If a connection between batteries appears the indications of earth fault control systems of both networks change.

8.5.3 Location of earth fault in direct current network using portable locator

The portable locator is employed to measure currents in the outgoings in which stationary measuring transformers are not installed. It is equipped with current pincers by which both

conductors (positive and negative) should be embraced during the measurements. The personnel measuring in turn the currents of individual outgoing locates an outgoing of worsened insulation resistance

Activation of device

To activate the device it is necessary to set a switch knob to the position ON. The device is deactivated at the position OFF. After the activation, a sign CAL appears on the display, it means that the device is ready for the calibration.



Calibration

Before the commencement of any measurement the device should be calibrated, i.e. synchronized with the operation of the stationary system. For this purpose it is necessary to hang pincers on the hanger in such a manner photodetector is in a black ring of the hanger.



One of the diodes on the hanger flashes green, the other "synchronization" diode blinks red in step of trial earth faults.

To push the START push button to start the calibration.

A symbol of rising edge appears on the display when the device receives the first impulse:



Two figures appear on the display during subsequent impulses. The figure on the left means the number of impulses to the completion of the calibration, however, the figure on the right means a duration of one impulse (in seconds).



In case when the device is arranged too far away or it is rearranged during the calibration a sign “Err” appears on the display.



The completion of the calibration is signalled by a double acoustic signal. The letter “P” (measurement) appears on the display, and the figures 1 and 0 blink alternately, synchronically to the generator operation in the central unit. It is a standby mode ready for measurements.



The measurements can be started after the completion of the calibration. The DC2-p locator must not be switched on during the measurements. If the locator is switched on or the supply of the central unit is disconnected during the measurements as well as when the measurements last longer than 8 hours the calibration should be repeated.

Performance of measurements

To start the measurement it is necessary to put the pincers on the conductors and to push the START push button.

The following symbol appears on the display:

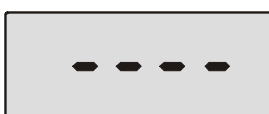

A screen occurs after about 25 seconds in which a left figure means the number of impulses to the completion of the measurement, however, the right figure means a duration of one impulse.



The completion of the measurement is signalled by a double acoustic signal. The figure (expressed in %) indicating the insulation condition of the measured outgoing, where “0” – means the earth fault ($I > 5\text{mA}$), “100” – means the lack of earth fault ($I < 2\text{mA}$), appears on the display.



The device performs two measurements one after another in order that the measured value is reliable. The average value of two measurements is shown on the display. If significant disturbances causing serious difference of the results appear during the measurements the sign “Err” is shown on the display. In such a case the measurement should be repeated.

If the device is not used for a longer time (e.g. during the movement between the switching stations) it is recommended to switch to the sleep condition through pushing the SLEEP push button. The sign SLP appears on the display and the figures 1 and 0 blink alternately, synchronically to the generator operation in the central unit.



In this condition the device is ready for the operation at a minimal energy consumption from the battery. In order to switch from the SLEEP mode to the MEASUREMENT mode it is necessary to push the START push button.

When a battery symbol appears during the measurements in the left top corner of the display,



the batteries should be replaced with new ones of LR44 type.

9 Operation

The DCtest2 system made by Energotest Ltd. is constructed in such a way that it does not require any special operation performance from the user.

9.1 Routine tests

At least twice a year there should be performed basic measurements of the system consisting in the measurement of ground resistance of the entire network and the measurements of ground resistance of several selected outgoings.

The routine tests within the scope of manufacture test should be performed every 3 years.

9.2 Detection and elimination of damage

In case any incorrectness in the operation of the DCtest2 system is found it is necessary to contact with a representative of the producer's service to achieve the instructions of further procedure.

There should be mentioned the following information when notifying damage to the producer's representative:

- type of device,
- production number,
- place of installation of device,
- symptoms of damage,
- name of responsible person,
- contact telephone number.

10 Transport and storage

The transport packing should have the same resistance degree to vibrations and shocks as specified in the standards PN-EN 60255-21-1 and PN-EN 60255-21-2 for the sharpness class 1.

The device delivered by the producer should be unpacked carefully, not using too much force inadequate tools. After unpacking it should be visually checked if the device has no outside damage.

The devices should be stored in a dry and clean place where the temperature of storage is within the range of from -25°C up to $+70^{\circ}\text{C}$.

The relative humidity should be within such a range to avoid condensation and frosting effects.

During a very long period of storage it is suggested each year to feed the device with auxiliary voltage for a period of two days in order to regenerate the electrolytic capacitors.

11 Utilization

If it is necessary to disassemble the device (and eventually to remove it), as a result of damage or operation life time finish than there should be previously switched off all the supplying values and other connections.

The disassembled devices should be treated as electronic scrap which should be utilized in accordance with the regulations concerning the waste management.

12 Warranty and service

For the delivered devices we grant 24-month warranty. In case the devices are activated by the specialists of Energotest Ltd. the warranty period is extended to 36 months. There is a possibility to

extend the warranty period. The maximum total warranty period amounts to 60 months. For every year of warranty period extension over 24 or 36 months it is necessary to calculate additional 2% of the mark-up for every 12 months of warranty period extension.

After the expiry of the basic warranty of 24, 36 or 60 months there is a possibility to extend the warranty period by next periods on condition that the payable tests are executed.

Note: For the products delivered abroad we grant warranty for delivered equipment, valid for 12 months since the activation of the devices, however, not longer than 18 months since the date of delivery, depending on the fact which time limit expires first. Within the framework of warranty we undertake to repair (at the Seller's place) or replace of damaged device or its part according to our own choice free of charge. All the removed devices or their parts are considered as our property if they are replaced with the other ones. The installation and transport of device or spare parts take place by effort and at the cost of the Orderer. The time limit of removal of defects notified within the framework of warranty is 30 days. In case of complicated repair or a need of import, this time limit is extended by necessary, documented time. We are not responsible for indirect losses and lost profits of the Orderer by virtue of failure of devices delivered by us and necessity to execute the warranty repair.

13 Ordering

The orders should be sent to the following address:

Energotest Ltd.

Chorzowska 44B; 44-100 Gliwice

phone: +48 32 270 45 18, fax: +48 32 270 45 17.

e-mail: sekretariat@energotest.com.pl

www.energotest.com.pl

The order should include: a version of central unit case, number/type of measuring transformers, number of concentrators and a name of person who can give additional information on a configuration of the direct current network among others.

In case of any doubts, in particular, within the scope of selection of optimal configuration of the DCtest2 system, we are at your disposal.